

ATTACHMENT T

EXPERT WITNESS REPORT - 2 January 2012 REVISION

Kline v. Loman Auto Group, Victoria Morgan-Alcala, et al.

Page Range 6

Pages 730 - 735

Defendant Lomans: Knowledge of Fuel System Defect Safety Recalls

On pages 20/21 of my Expert Witness Report - First Revision of 28 April 2011, I state

“O&C-3 In my expert experience I have personally/professionally examined the consumer response to safety recalls. This response rate, or yield, is dependant on the safety issue involved and, although the precise statistics are claimed to be a “trade secret” by the automotive industry, it is well-known that the highest safety defect recall yield by far correlates to customer notices that involve the elimination/reduction of a vehicle fire risk:

a. I am confident that if the SUSAN MORRIS KLINE family had been made aware of the salient facts contained in the main portion of this report and was offered, in a formal Chrysler recall, a retrofit that afforded the protection of a “Fuel Tank Skid Plate Shield,” they would have responded responsibly by having their 1996 Jeep Grand Cherokee retrofitted by a competent Jeep dealer (See ¶ 21-c-i):

i. The issuance-of and service response-to safety defect retrofit recalls is well-known to defendant Loman Auto Group. Approximately five years prior to the accident of February 24, 2007 that took the life of SUSAN MORRIS KLINE, defendant Loman Auto Group was notified of, and potentially performed fire-related retrofits of a competitive brand (e.g. Service Part Numbers 3W7Z-9B007-AA, 3W7Z-9B007-BA and 3W7Z-9B007-CA).”

The fuel tank on the “Panther” versions of the Ford Crown Victoria, Mercury Grand Marquis and Lincoln Town Car locate the fuel tank slightly aft and above the rear axle. These vehicles, in the police/emergency configuration, were part of a NHTSA defect investigation on the basis of rear end accident collisions that resulted in fuel tank failure, fire/explosions, and the severe burn injury or death of occupants. Unlike the ZJ-Body Jeep Grand Cherokee, these Panther fuel tanks are not exposed below the rear bumper, and are not subject to direct impact. However, in view of real-world facts, Ford voluntarily recalled the Panther vehicles for retrofit.

Ford through its dealerships, although officially making the retrofit available to police and emergency vehicles, will also provide for sale to the general public Service Part Numbers 3W7Z-9B007-AA, 3W7Z-9B007-BA and 3W7Z-9B007-CA. Ford dealership mechanics, such as those at Lomans Auto Group, can perform this retrofit in less than 30 minutes.

According to Ford this retrofit will provide fuel tank safety integrity up 65mph. This minimum level of protection should have been made available to the owners of the ZJ-Body Jeep Grand Cherokee, and retrofit to such levels was/is possible. In its current unprotected configuration, vehicles such as the 1996 Jeep Grand Cherokee, which were operated by Mrs. Susan Kline and serviced by Lomans, do not provide protection for very low speed impacts.

Regarding O&C-3-a-i, I have personally performed this retrofit on my 1997 Ford Crown Victoria vehicle, on my back in my driveway. This retrofit required simple hand tools, a floor jack and safety stands (Please see sub-attached photographs).



**CROWN VICTORIA POLICE INTERCEPTOR (CVPI)
PACKAGE OPTIONAL UPGRADE KIT**

AFFECTED VEHICLES: CERTAIN 1992 THROUGH 2003 MODEL YEAR CROWN VICTORIA
POLICE INTERCEPTOR (CVPI) VEHICLES
CURRENTLY IN POLICE DUTY

**2003 MODEL YEAR VEHICLES
SERVICE PART NUMBER 3W7Z-9B007-AA**

KIT CONTENTS:

<u>Part Number</u>	<u>Description</u>	<u>Quantity</u>
-9N070-	Shield, Fuel Tank Strap - RH	1
-9C170-	Shield, Fuel Tank Strap - LH	2
-9F935-	Pads, Canister Buffer	5
W704369-S309	Rivet, Carbon Canister	1
-4C036-	Shield, Differential	3
-4346-	Bolt, Differential Shield Hex Head	1
-4A389-	Shield Assembly, Axle - RH	1
-4C035-	Shield Assembly, Axle - LH	1
-19G376-	Instruction Sheet	1

**1998-2002 MODEL YEAR VEHICLES
SERVICE PART NUMBER 3W7Z-9B007-BA**

KIT CONTENTS:

<u>Part Number</u>	<u>Description</u>	<u>Quantity</u>
-9N070-	Shield, Fuel Tank Strap - RH	1
-9C170-	Shield, Fuel Tank Strap - LH	1
-9F935-	Pads, Canister Buffer	2
W704369-S309	Rivet, Carbon Canister	5
-4C036-	Shield, Differential	1
-4346-	Bolt, Differential Shield Hex Head	3
-4A389-	Shield Assembly, Axle - RH	1
-4C035-	Shield Assembly, Axle - LH	1
W709586S-300	Strap, Tie	2
-19G376-	Instruction Sheet	1

**1992-1997 MODEL YEAR VEHICLES
SERVICE PART NUMBER 3W7Z-9B007-CA**

KIT CONTENTS:

<u>Part Number</u>	<u>Description</u>	<u>Quantity</u>
-9N070-	Shield, Fuel Tank Strap - RH	1
-9C170-	Shield, Fuel Tank Strap - LH	2
-9F935-	Pads, Canister Buffer	5
W704369-S309	Rivet, Carbon Canister	1
-4C036-	Shield, Differential	3
-4346-	Bolt, Differential Shield Hex Head	1
-4A389-	Shield Assembly, Axle - RH	1
-4C035-	Shield Assembly, Axle - LH	1
-19G376-	Instruction Sheet	1



**CROWN VICTORIA POLICE INTERCEPTOR (CVP)
PACKAGE OPTIONAL UPGRADE KIT**

AFFECTED VEHICLES: CERTAIN 1992-1997 MODEL YEAR CROWN VICTORIA
POLICE INTERCEPTOR (CVP) VEHICLES
CURRENTLY IN POLICE DUTY

2003 MODEL YEAR VEHICLES
SERVICE PART NUMBER 3N7Z-9B007-1A
KIT CONTENTS:

Part Number	Description	Quantity
3N7Z-9B007-1A	Shield, Front Interceptor - RH	1
3N7Z-9B007-1A	Shield, Front Interceptor - LH	1
3N7Z-9B007-1A	Shield, Center Interceptor	1
3N7Z-9B007-1A	Shield, Rear Interceptor	1
3N7Z-9B007-1A	Shield, Rear Interceptor - RH	1
3N7Z-9B007-1A	Shield, Rear Interceptor - LH	1
3N7Z-9B007-1A	Shield, Rear Interceptor - RH	1
3N7Z-9B007-1A	Shield, Rear Interceptor - LH	1
3N7Z-9B007-1A	Shield, Rear Interceptor - RH	1
3N7Z-9B007-1A	Shield, Rear Interceptor - LH	1

1992-1997 MODEL YEAR VEHICLES
SERVICE PART NUMBER 3N7Z-9B007-1A
KIT CONTENTS:

Part Number	Description	Quantity
3N7Z-9B007-1A	Shield, Front Interceptor - RH	1
3N7Z-9B007-1A	Shield, Front Interceptor - LH	1
3N7Z-9B007-1A	Shield, Center Interceptor	1
3N7Z-9B007-1A	Shield, Rear Interceptor	1
3N7Z-9B007-1A	Shield, Rear Interceptor - RH	1
3N7Z-9B007-1A	Shield, Rear Interceptor - LH	1
3N7Z-9B007-1A	Shield, Rear Interceptor - RH	1
3N7Z-9B007-1A	Shield, Rear Interceptor - LH	1

<ul style="list-style-type: none"> • BODY—PARTS AND PROCEDURE TO REDUCE THE POTENTIAL OF FUEL TANK PUNCTURES DURING RARE AND EXTREMELY HIGH-SPEED REAR IMPACTS • FUEL— PARTS AND PROCEDURE TO REDUCE THE POTENTIAL OF FUEL TANK PUNCTURES DURING RARE AND EXTREMELY HIGH-SPEED REAR IMPACTS 	Article No. 01-21-14
---	---------------------------------

FORD: 1992-2001 CROWN VICTORIA
LINCOLN: 1992-2001 TOWN CAR
MERCURY: 1992-2001 GRAND MARQUIS

ISSUE

This article is being issued to provide Service Parts and a Service Procedure to further reduce the unlikely possibility of a fuel tank puncture during an extremely high-speed rear impact in certain vehicle applications. Some Police agencies have indicated that their vehicles may stop along high-speed roads - which is prohibited by law except in emergency situations - and may thereby become exposed to extremely high-speed rear impacts, typically by drunk drivers.

Ford corporate guideline tests, at speeds 20 mph above government requirements, demonstrate excellent fuel tank integrity in these vehicles. Because of the nature of their use, some Police vehicles in certain applications may be exposed to extremely high-speed rear impacts with closing speeds above 80 mph. Investigation of several police vehicles involved in extreme high-speed rear impacts has identified a potential cause of the fuel tank puncture in at least one of these impacts.

ACTION

Recommended for vehicles exposed to extremely high-speed rear impacts. Refer to the following Service Procedure for details.

SERVICE PROCEDURE

1. On 1992-1997 vehicles, replace Park Brake Cable to Axle attaching hex head bolt part N806900-S2 with round-headed fastener part W706024-S427. Model year 1998 and later vehicles are of a different design and do not use this bolt (Figure 1).

2. On 1992-2001 vehicles, use a die grinder or electric grinder with suitable carbide or grinding wheel to remove the 4 mm high by 6 mm wide tab which protrudes down from one flange of the rear stabilizer bar axle attachment "U" bracket. There is a "U" bracket at each end of the center section of the rear stabilizer bar (Figure 2).

The "U" brackets do not need to be removed from the vehicle.

The tab should be ground until it is flush with the contour of the flange.

PART NUMBER	PART NAME
W706024-S427	Bolt - Round Headed Fastener

OTHER APPLICABLE ARTICLES: NONE
WARRANTY STATUS: Eligible Under The Provisions Of Bumper To Bumper Warranty Coverage

OPERATION	DESCRIPTION	TIME
012114A	Replace Park Brake Cable To Axle Attaching Hex Head Fastener With Round Headed Fastener, Then Grind Tab From Both U-Brackets On Rear Stabilizer Bar 1992-1997	0.4 Hr.
012114B	Grind Tab From Both U-Brackets On Rear Stabilizer Bar 1992-2001	0.2 Hr.

CRUZ
F 030541

1271

Article No. 01-21-14 Cont'd.

DEALER CODING

BASIC PART NO.

4A047

OASIS CODES: 111000, 404000, 509000

CONDITION

CODE

42

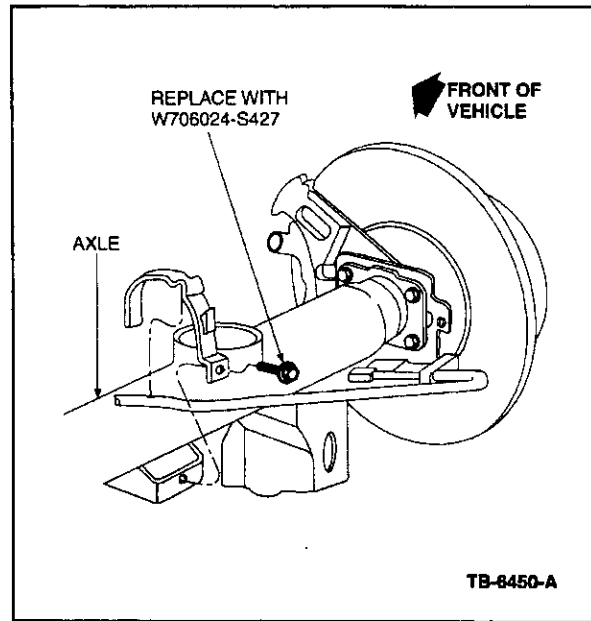

Figure 1 - Article 01-21-14

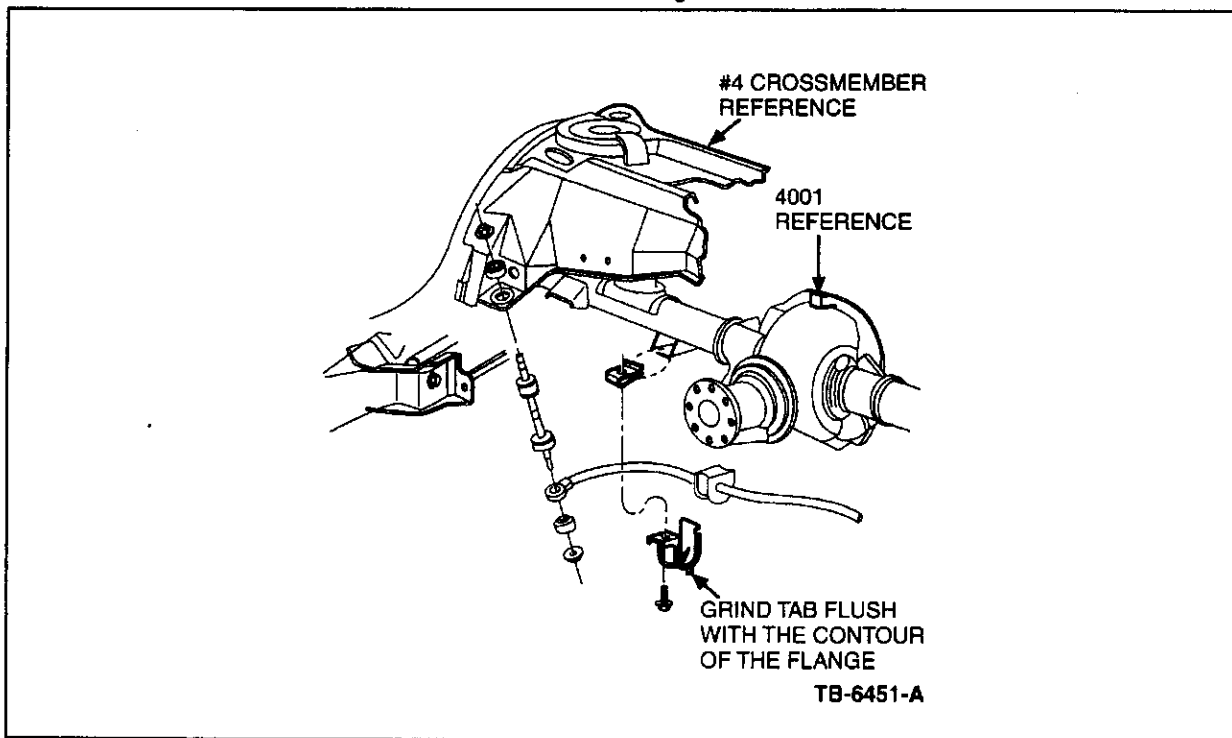

Figure 2 - Article 01-21-14