

EXPERIMENTAL TEST OF OCCUPANT ENTRAPMENT

FORD TAURUS INTO REAR OF FORD EXPLORER

75 MPH

Test Date: September 28, 2010

Final Report Date: September 30, 2010

SECTION 1

PURPOSE AND SUMMARY OF TEST

PURPOSE

The purpose of this 75 mph rear impact test is to examine the occurrence of occupant entrapment in high-speed rear impacts.

SUMMARY

A 1998 Ford Explorer was impacted in the rear by a 2001 Ford Taurus at a velocity of 75 mph. The test was performed at the Federal Outdoor Impact Laboratory on September 28, 2010.

Three real time cameras and nine high-speed cameras were used to document the rear impact event.

One 50th percentile male anthropomorphic test device (ATD) was placed in the driver seating position of the Explorer and One 50th percentile male anthropomorphic test device (ATD) was placed in the driver seating position of the Taurus. Both ATDs were positioned approximately according to dummy placement instructions specified in the FMVSS 208 Laboratory Indicant Test Procedure.

The ATD in the Explorer was instrumented for this test. The ATD in the Taurus was uninstrumented for this test.

The 46 channels of data were recorded with an on-board data acquisition system.

SECTION 2

OCCUPANT AND VEHICLE INFORMATION / DATA SHEETS

DATA SHEET NO. 1

BULLET VEHICLE CRASH TEST SUMMARY

Bullet Vehicle: 2001 Ford Taurus
Test Program: 75 mph Rear Impact Test Test Date: 9/28/10

BULLET VEHICLE PRIMARY IMPACT DATA

Measured Parameter	Units	Value
Bullet Vehicle Velocity At Impact	kph	121
Bullet Vehicle Test Weight	kg	1516
Bullet Vehicle Maximum Static Crush	mm	
Impact Point	mm	0

DOOR OPENING AND SEAT TRACK INFORMATION: BULLET VEHICLE

Description	Driver	Passenger
Front Door Opening	Crush Resistance	Crush Resistance
Rear Door Opening	Fully Functional	Fully Functional
Seat Track Shift (mm)	None	-
Seat Back Failure (deg)	None	-

TEST DUMMY INFORMATION: BULLET VEHICLE

Description	Driver	Passenger
Dummy Type	HII 50th	-
Head Contact	Airbag	-
Chest Contact	-	-
Abdomen Contact	-	-
Left Knee Contact	Knee Bolster	-
Right Knee Contact	-	-

VIDEO COVERAGE

High Speed	9
Real Time	3
Total	12

Driver ATD Sensors	25 (Target Vehicle ATD Only)
Passenger ATD Sensors	-
Bullet Vehicle Structure Accelerometers	9
Target Vehicle Structure Accelerometers	12
Total	46

DATA SHEET NO. 2

GENERAL TEST AND BULLET VEHICLE PARAMETER DATA

Bullet Vehicle: 2001 Ford Taurus

Test Program: 75 mph Rear Impact Test

Test Date: 9/28/10

BULLET VEHICLE INFORMATION

Manufacturer	Ford
Model	Taurus
Body Style	4Dr Sedan
Vehicle No.	1
VIN	1FAFP55U41A180860
Color	Blue
Delivery Date	
Odometer Reading	137,769
Dealer	Capital Auto Auctions
Transmission	Automatic
Final Drive	FWD
Number of Cylinders	6
Engine Displacement (L)	3.0L
Engine Placement	Transverse

TEST VEHICLE OPTIONS

Driver Airbag	Y
Passenger Airbag	Y
Anti-theft System	Y
Cruise Control	Y
Power Windows	Y
Power Steering	Y
Power Door Locks	Y
Tilt Wheel	Y
Air Conditioning	Y
Power Brakes	Y
Disc Brakes, Front	Y
Disc Brakes, Rear	Drum
Anti-lock Brakes	Y
AM / FM / Cassette	Y

DATA FROM CERTIFICATION LABEL

Manufactured By	Ford Motor Company
Date of Manufacture	12/00

GVWR (kg)	2124 kg
GAWR Front (kg)	1168 kg
GAWR Rear (kg)	967 kg

DATA FROM TIRE PLACARD

Measured Parameter	Front	Rear
Maximum Tire Pressure (psi)		
Cold Pressure (psi)	30 psi	30 psi
Recommended Tire Size	P215/60R16	P215/60R16
Tire Size On Vehicle		
Tire Manufacturer		

Measured Parameter	Front	Rear	Third	Total
Type of Seats	Bucket / Bench	Bench	NA	
Number of Occupants	3	3	NA	6
Capacity Wt. (VCW) (kg)				499 kg
Cargo Wt. (RCLW) (kg)				

DATA SHEET NO. 3

BULLET VEHICLE PARAMETER DATA

Bullet Vehicle: 2001 Ford Taurus
Test Program: 75 mph Rear Impact Test Test Date: 9/28/10

BULLET VEHICLE WEIGHTS

	Units	As Delivered (UVW) (Axle)			As Tested (ATW) (Axle)		
		Front	Rear	Total	Front	Rear	Total
Left	kg	481.5	242.5	724.0	494.0	293.0	787.0
Right	kg	449.50	254.5	704.0	441.0	288.0	729.0
Ratio	%	65%	35%	-	62%	38%	-
Totals	kg	931.0	497.0	1428.0	935.0	581.0	1516.0

BULLET VEHICLE TARGET TEST WEIGHT CALCULATION

Measured Parameter	Units	Value
Total Delivered Weight	kg	1428.0
Weight of 1 P572E ATD	kg	70.0
Rated Cargo / Luggage Weight (RCLW)	kg	
Calculated Vehicle Target Weight (TVTW)	kg	1498.0

BULLET VEHICLE ATTITUDES

	Units	LF	RF	LR	RR
As Delivered	mm	-	-	-	-
As Tested	mm	703	708	715	720
Post Test	mm	841	692	702	740

Weight of Ballast: _____

Vehicle Components Removed: Oil, Transmission fluid, coolant, gas

Weight Removed: 27.5 kg

Added: Data Acquisition, Battery box, Instrument Tray,
Brake System, Dummy

Weight Added: 115.5 kg

DATA SHEET NO. 4

BULLET VEHICLE TIRE INFORMATION

Bullet Vehicle: 2001 Ford Taurus

Test Program: 75 mph Rear Impact Test

Test Date: 9/28/10

Vehicle Year		Vehicle Make	Ford
VIN		Vehicle Model	Taurus

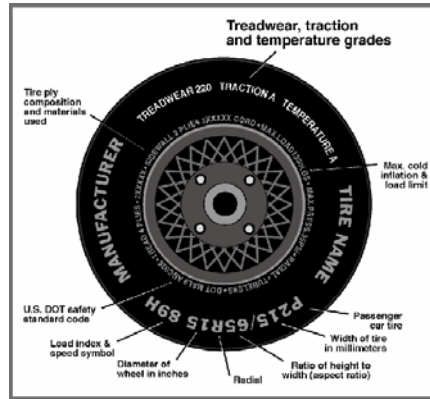

	Left Front	Right Front
Tire Manufacturer	Mastercraft	Mastercraft
Tire Name	Strategy	Strategy
Tire Type	Radial	Radial
Tire Width (mm)	P215	P215
Ratio of Height to Width (aspect ratio)	60	60
Radial	R	R
Wheel Diameter	16	16
Load Index & Speed Symbol		
Treadwear	540	540
Traction Grade	A	A
Temperature Grade	B	B
	Left Rear	Right Rear
Tire Manufacturer	Mastercraft	Mastercraft
Tire Name	Strategy	Strategy
Tire Type	Radial	Radial
Tire Width (mm)	P215	P215
Ratio of Height to Width (aspect ratio)	60	60
Radial	R	R
Wheel Diameter	16	16
Load Index & Speed Symbol		
Treadwear	540	540
Traction Grade	A	A
Temperature Grade	B	B

DATA SHEET NO.

BULLET VEHICLE SEAT INFORMATION

Bullet Vehicle: 2001 Ford Taurus

Test Program: 75 mph Rear Impact Test

Test Date: 9/28/10

NORMAL DESIGN RIDING POSITION

Driver Seat Back Angle: 30 deg

Passenger Seat Back Angle: deg

(70 deg full up / 45 deg full down)

SEAT FORE / AFT POSITION

The driver and passenger seats are operated:
(manually / **electrically**)

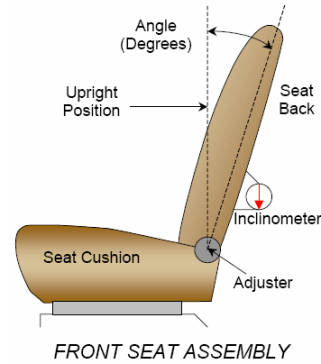

Driver Seat Fore / Aft Total Travel: 254 positions / **mm**

Passenger Seat Fore / Aft Total Travel: positions / **mm**

As Tested:

Driver Seat Fore / Aft Position: 127 mm rearward of full forward

Passenger Seat Fore / Aft Position: _____

SEAT BELT UPPER ANCHORAGE

The seat belt anchorages were placed in 3 position of 5 with the top position as one.

or No Adjustment Available

SEAT HEIGHT ADJUSTMENT

Seat is positioned at its lowest setting

NOTES: _____

DATA SHEET NO. ... (continued)

BULLET VEHICLE INFORMATION

Bullet Vehicle: 2001 Ford Taurus

Test Program: 75 mph Rear Impact Test

Test Date: 9/28/10

STEERING COLUMN ADJUSTMENT

The steering column was placed in the mid position of travel.

Pos.	Desc	Angle
3	Full Up	<u>65 deg</u>
2	Center	<u>72.5 deg</u>
1	Full Down	<u>80 deg</u>

As Tested 75 deg

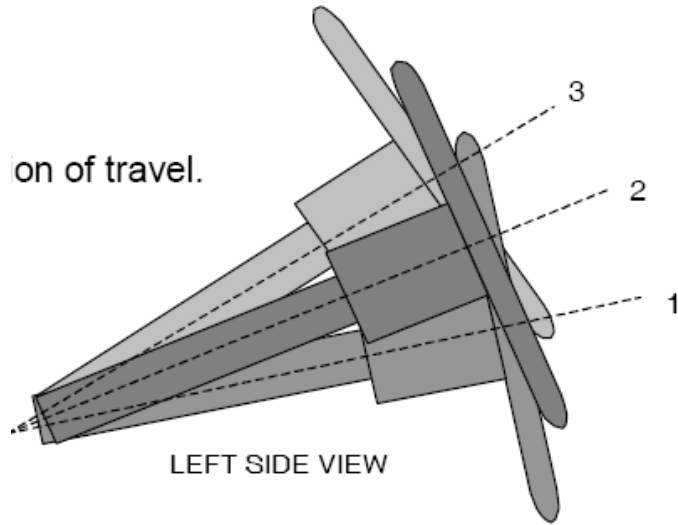

STEERING COLUMN ASSEMBLY

DATA SHEET NO.

BULLET VEHICLE DUMMY POSITIONING IN VEHICLE

Bullet Vehicle: 2001 Ford Taurus

Test Program: 75 mph Rear Impact Test

Test Date: 9/28/10

DUMMY MEASUREMENTS FOR FRONT SEAT OCCUPANTS

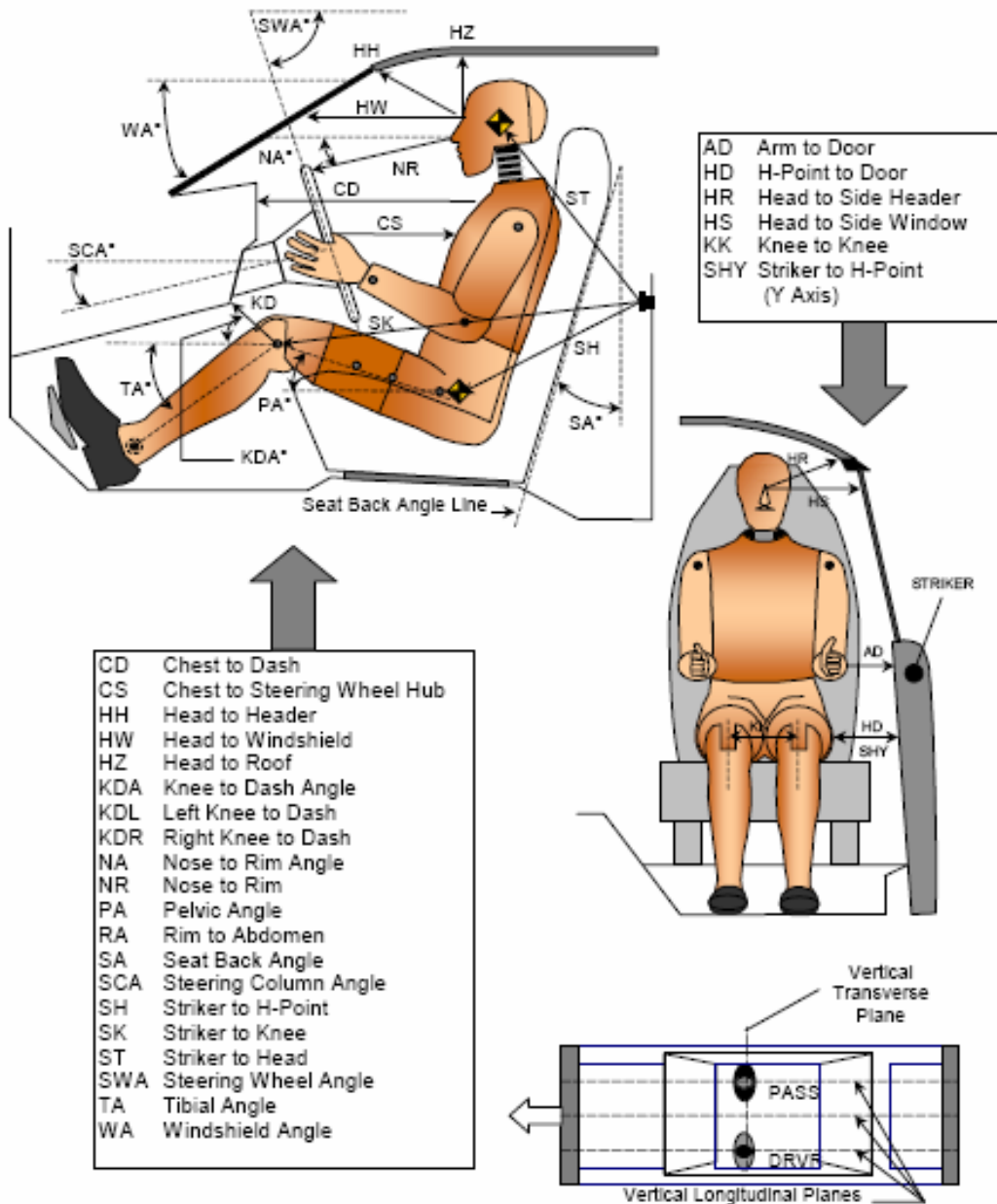

DATA SHEET NO. ...(continued)

BULLET VEHICLE DUMMY POSITIONING IN VEHICLE

Bullet Vehicle: 2001 Ford Taurus

Test Program: 75 mph Rear Impact Test

Test Date: 9/28/10

Code	Measurement Description	Driver		Passenger	
		Length (mm)	Angle (°)	Length (mm)	Angle (°)
WA	Windshield Angle		25		
SWA	Steering Wheel Angle		75		
SCA	Steering Column Angle		15		
SA	Seat Back Angle (head rest post)		25		
HZ	Head to Roof (Z)	250			
HH	Head to Header	470			
HW	Head to Windshield	770			
HR	Head to Side Header (Y)	240			
NR	Nose to Rim	510			
CD	Chest to Dash	610			
CS	Chest to Steering Hub	290			
RA	Rim to Abdomen	n/a			
KDL	Left Knee to Dash	120			
KDR	Right Knee to Dash	40			
PA	Pelvic Angle	n/a			
TA	Tibia Angle	n/a			
KK	Knee to Knee (Y)	300			
SK	Striker to Knee	n/a			
ST	Striker to Head	n/a			
SH	Striker to H-Point	n/a			
SHY	Striker to H-Point (Y)	n/a			
HS	Head to Side Window	350			
HD	H-Point to Door	160			
AD	Arm to Door (Y)	30			
AA	Ankle to Ankle	n/a			

DATA SHEET NO. 16

BULLET VEHICLE SEAT BELT POSITIONING DATA

Bullet Vehicle: 2001 Ford Taurus

Test Program: 75 mph Rear Impact Test

Test Date: 9/28/10

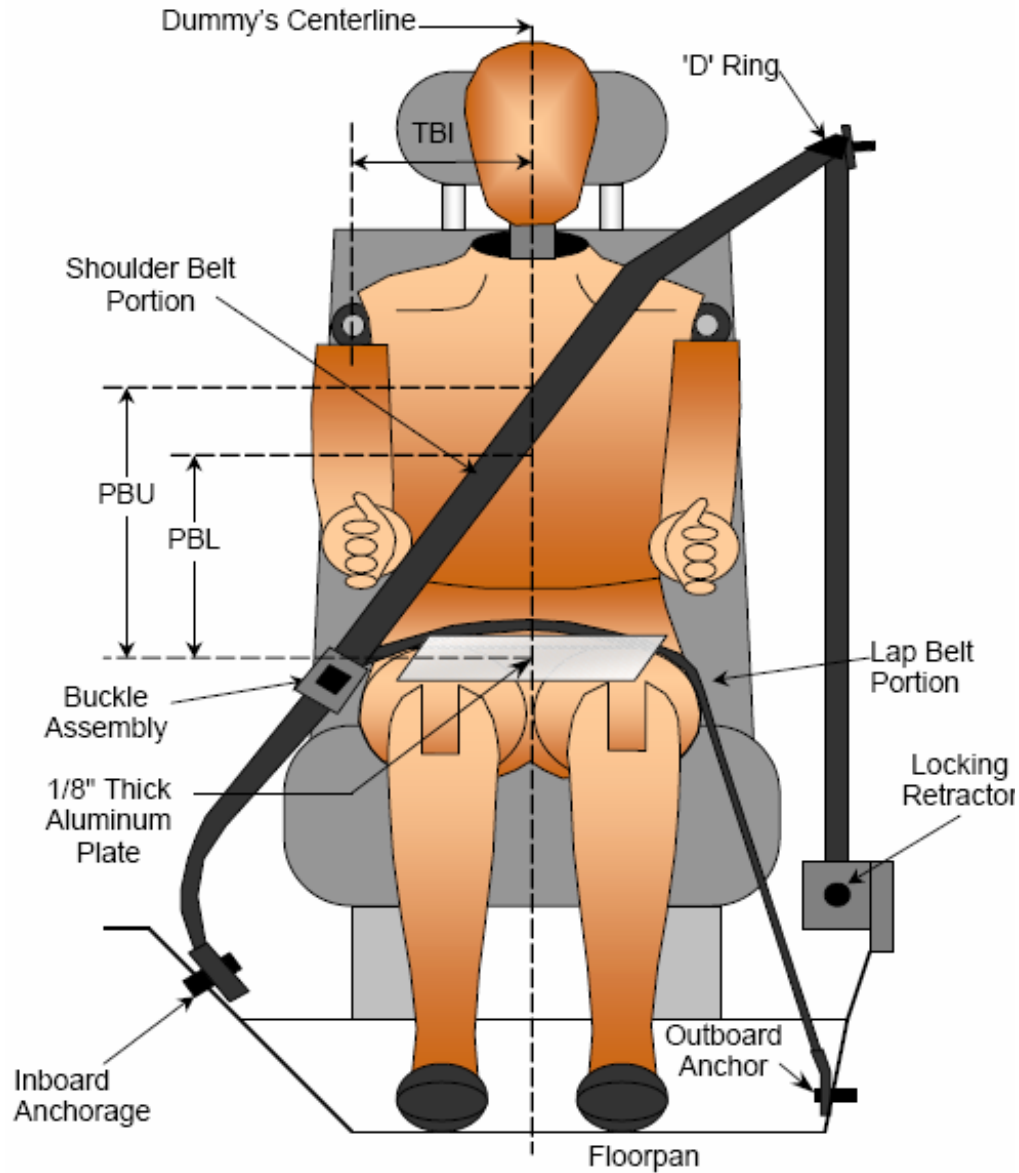

SEAT BELT POSITIONING MEASUREMENTS

Measurement Description	Units	Driver	Passenger
PBU – Top surface of reference to belt upper edge	mm	-	
PBL – Top surface of reference to belt lower edge	mm	-	

DATA SHEET NO. 5

BULLET VEHICLE MEASUREMENTS

Bullet Vehicle: 2001 Ford Taurus

Test Program: 75 mph Rear Impact Test

Test Date: 9/28/10

No.	Measurement	Units	Pre-Test	Post-Test	Diff
1	Total length of vehicle at centerline	mm	5004	4636	368
2	RSOV to front of engine	mm	4394	4369	25
3	RSOV to firewall centerline	mm	3785	3708	77
4	RSOV to leading edge of right door	mm	3473	3442	31
5	RSOV to leading edge of left door	mm	3480	3480	0
6	RSOV to lower leading edge of right door	mm	3404	3404	0
7	RSOV to lower leading edge of left door	mm	3404	3404	0
8	RSOV to upper leading edge of right door	mm	3442	3429	13
9	RSOV to upper leading edge of left door	mm	3442	3442	0
	RSOV to trailing edge of right door	mm	2375	2362	13
	RSOV to trailing edge of left door	mm	2350	2375	-25
10	RSOV to lower trailing edge of right door	mm	2324	2324	0
11	RSOV to lower trailing edge of left door	mm	2337	2324	13
	RSOV to upper trailing edge of right door	mm	2350	2337	13
	RSOV to upper trailing edge of left door	mm	2362	2350	12
	RSOV to trailing edge of rear right door	mm	1549	1562	-13
	RSOV to trailing edge of rear left door	mm	1562	1549	13
	RSOV to lower trailing edge of rear right door	mm	1638	1638	0
	RSOV to lower trailing edge of rear left door	mm	1651	1638	13
	RSOV to upper trailing edge of rear right door	mm	1384	1397	-13
	RSOV to upper trailing edge of rear left door	mm	1397	1410	-13
12	RSOV to bottom of right 'A' pillar	mm	3404	3391	13
13	RSOV to bottom of left 'A' pillar	mm	3416	3416	0
	RSOV to bottom of right 'B' pillar	mm	2388	2388	0
	RSOV to bottom of left 'B' pillar	mm	2400	2400	0
	RSOV to bottom of right 'C' pillar	mm	1651	1638	13
	RSOV to bottom of left 'C' pillar	mm	1670	1664	6
14	RSOV to firewall on right side	mm	3683	3696	-13
15	RSOV to firewall on left side	mm	3677	3531	146
16	RSOV to steering column	mm	2972	2959	13
17	Center of steering column to left 'A' pillar	mm	292	483	-191
18	Center of steering column to headlining	mm	406	432	-26
19	RSOV to right side of front bumper	mm	4623	4686	-63
20	RSOV to left side of front bumper	mm	4623	4470	153
21	Length of Engine Block	mm			
RD	RSOV to right side of dash panel	mm	3086	3112	-26
CD	RSOV to center of dash panel	mm			
LD	RSOV to left side of dash panel	mm	3099	3099	0

DATA SHEET NO. 5... (continued)

BULLET VEHICLE MEASUREMENTS

Bullet Vehicle:

2001 Ford Taurus

Test Program:

75 mph Rear Impact Test

Test Date: 9/28/10

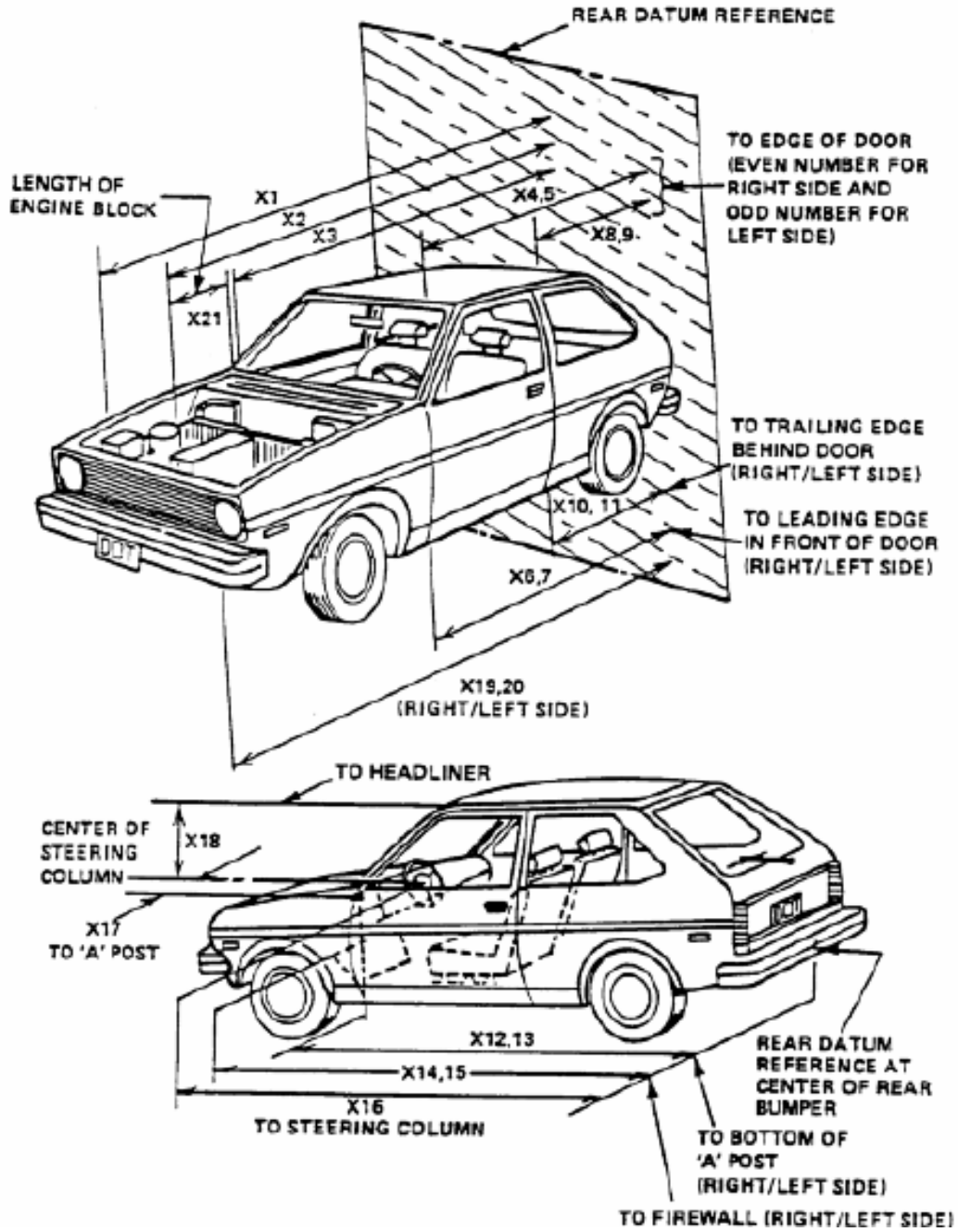

DATA SHEET NO. 5... (Continued)

BULLET VEHICLE MEASUREMENTS

Bullet Vehicle: 2001 Ford Taurus

Test Program: 75 mph Rear Impact Test

Test Date: 9/28/10

	Elements	Measurement (mm)
1	Total Length	5004
2	Total Width	1778
3	Front Bumper Top Height	533
4	Front Bumper Bottom Height	368
5	Longitudinal Member Top Height	
6	Distance Between Longitudinal Members	
7	Longitudinal Member Width	
8	Engine Top Height	
9	Engine Bottom Height	
10	Engine and Gearbox Width	
11	Front Bumper – Engine Distance	
12	Front Shock Absorber Fixing Height	864
13	Bonnet Leading Edge Height	686
14	Front Shock Absorber Fixing Width	1130
15	Front Axle Location from RSOV	3962
16	Rear Axle Location from RSOV	1194
17	Front Axle Location	3962
18	Rear Axle Location	1194
19	B-Pillar – C-Pillar Distance	
20	Roof Sill Bottom Height	1321
21	Roof Sill Top Height	1422
22	Floor Sill Bottom Height	191
23	Floor Sill Top Height	279

DATA SHEET NO. 6

BULLET VEHICLE ACCELEROMETER LOCATIONS & MEASUREMENTS

Bullet Vehicle: 2001 Ford Taurus

Test Program: 75 mph Rear Impact Test

Test Date: 9/28/10

Location	X (mm)	Y (mm)	Z (mm)
CG	2946	864	343

X Reference from the rear bumper – positive towards the front of the vehicle

Y Reference from the passenger's – positive towards the driver's side of the vehicle

Z Reference from the ground – positive up

Description of Instrumentation Included:

DATA SHEET NO. 7

BULLET VEHICLE PHOTOGRAPHIC REFERENCE TARGET LOCATIONS

Bullet Vehicle: 2001 Ford Taurus

Test Program: 75 mph Rear Impact Test

Test Date: 9/28/10



Side Marker Measurements

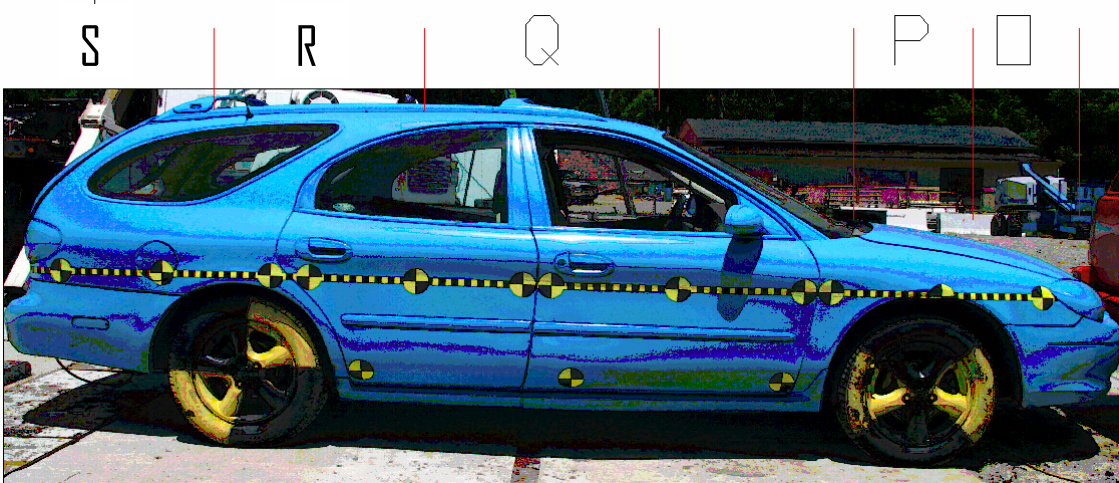

Top Marker Measurements

DATA SHEET NO. 7

BULLET VEHICLE PHOTOGRAPHIC REFERENCE TARGET LOCATIONS

Bullet Vehicle: 2001 Ford Taurus

Test Program: 75 mph Rear Impact Test

Test Date: 9/28/10

	Driver's Side Middle		Passenger's Side Middle	
	Pre	Post	Pre	Post
A	440	279	436	419
B	439		440	425
C	109		110	106
D	502	498	495	494
E	498	495	502	500
F	111	108	113	108
G	432	435	461	460
H	455	451	436	435
I	143	141	140	138
J	452	451	455	454
K	456	452	458	452
	Driver's Side Low		Passenger's Side Low	
L	-	-	-	-
M	-	-	-	-
	Top			
	Pre		Post	
O	473		229	
P	466		438	
Q	755		759	
R	744		737	
S	432		432	

DATA SHEET NO. 8

BULLET VEHICLE INTRUSION MEASUREMENTS

Bullet Vehicle: 2001 Ford Taurus

Test Program: 75 mph Rear Impact Test

Test Date: 9/28/10

DOOR OPENING WIDTH

Item	Description	Units	Pre-Test	Post-Test	Difference
A	Left Side Upper	mm	927	914	13
B	Left Side Lower	mm	908	902	6
D	Right Side Upper	mm	927	927	0
E	Right Side Lower	mm	902	895	7
	Rear Left Side Upper	mm	914	914	0
	Rear Left Side Lower	mm	610	610	0
	Rear Right Side Upper	mm	914	914	0
	Rear Right Side Lower	mm	597	597	0

WHEELBASE MEASUREMENTS

Item	Description	Units	Pre-Test	Post-Test	Difference
C	Left Side Wheelbase	mm	2769	2692	76
F	Right Side Wheelbase	mm	2769	2743	25

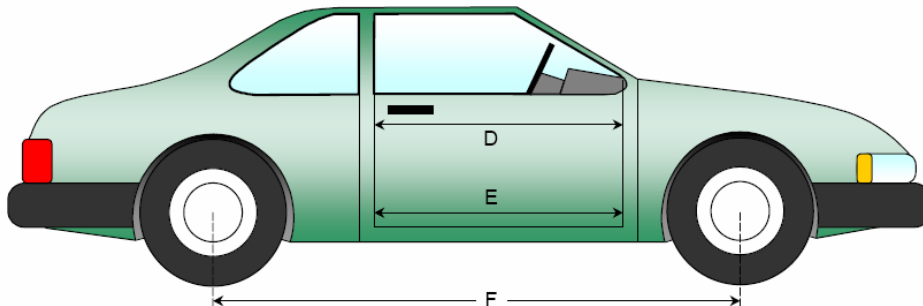
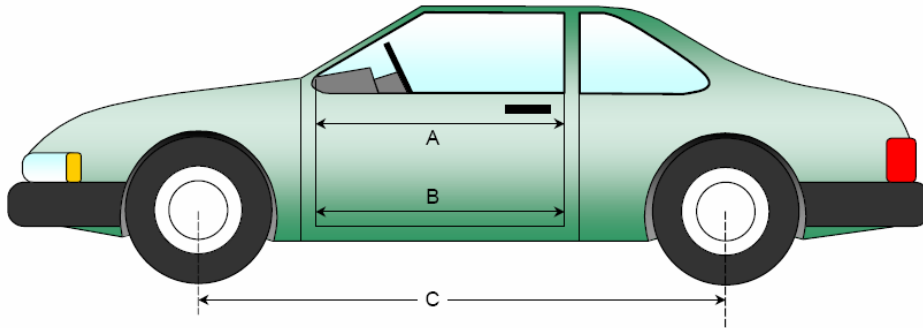

DATA SHEET NO. 9

BULLET VEHICLE ACCIDENT INVESTIGATION DIVISION DATA

Bullet Vehicle: 2001 Ford Taurus
 Test Program: 75 mph Rear Impact Test Test Date: 9/28/10

VEHICLE INFORMATION

VIN: 1FAFP55U41A180860 Wheelbase (mm): 2769
 Vehicle Size Category: _____ Test Weight (kg): _____

ACCELEROMETER DATA

Accelerometer Locations: approximate c.g. location, see accel data sheet
 Cal. Procedure / Interval: -
 Integration Algorithm: - Linearity: -
 Impact Velocity (kph): 121 kph
 Velocity Change (kph): 72.4 kph Time of Separation (ms): 78

CRUSH PROFILE

Collision Deformation Classification: 12FDEW2 Midpoint of damage 0
 Damage Region Length (mm): 1575 Impact Mode: frontal

At Bumper: z = 533 (bumper) mm (y pos, x pos or crush)

No.	Measurement Description	Units	Pre-Test	Post-Test	Difference
C1	Crush Zone 1 at left side	Mm	102,305	102,NA	-
C2	Crush Zone 2 at left side	Mm	417,60	417,305	245
C3	Crush Zone 3 at left side	Mm	732,0	732,356	356
C4	Crush Zone 4 at Right Side	Mm	1046,0	1046,419	419
C5	Crush Zone 5 at Right Side	Mm	1361,60	1361,457	397
C6	Crush Zone 6 at Right Side	Mm	1676, 305	1676,NA	
L	C1 to C6	Mm	1575	-	-

At top of radiator, marked bolts (under ride): z = _____ mm (y pos, x pos or crush)

No.	Measurement Description	Units	Pre-Test	Post-Test	Difference
C1	Crush Zone 1 at left side	Mm	229,457	229,483	26
C2	Crush Zone 2 at left side	Mm	457,343	457,533	190
C3	Crush Zone 3 at left side	Mm	787,318	787,470	152
C4	Crush Zone 4 at Right Side	Mm	991,318	991,432	114
C5	Crush Zone 5 at Right Side	Mm	1321,343	1321,508	165
C6	Crush Zone 6 at Right Side	Mm	1549,457	1549,867	410
L	C1 to C6	Mm	1321	-	-

Y = 0 at driver's side

DATA SHEET NO. 10

TARGET VEHICLE CRASH TEST SUMMARY

Target Vehicle: 1998 Ford Explorer

Test Program: 75 mph Rear Impact Test

Test Date: 9/28/10

TARGET VEHICLE PRIMARY IMPACT DATA

Measured Parameter	Units	Value
Target Vehicle Velocity At Impact	kph	0.0
Target Vehicle Test Weight	kg	1951
Target Vehicle Maximum Static Crush	mm	648
Impact Point	mm	0

DOOR OPENING AND SEAT TRACK INFORMATION: TARGET VEHICLE

Description	Driver	Passenger
Front Door Opening	Crush locked	Crush resistance
Rear Door Opening	Functional	Crush resistance
Seat Track Shift (mm)	Full rear	-
Seat Back Failure (deg)	Full recline	-

TEST DUMMY INFORMATION: TARGET VEHICLE

Description	Driver	Passenger
Dummy Type	HIII – instrumented	-
Head Contact	With rear seatback	-
Chest Contact		-
Abdomen Contact		-
Left Knee Contact		-
Right Knee Contact		-

VIDEO COVERAGE

High Speed	9
Real Time	2
Total	11

Driver ATD Sensors	25 (target vehicle only)
Passenger ATD Sensors	-
Bullet Vehicle Structure Accelerometers	9
Target Vehicle Structure Accelerometers	12
Total	46

DATA SHEET NO. 11

GENERAL TEST AND TARGET VEHICLE PARAMETER DATA

Target Vehicle: 1998 Ford Explorer
 Test Program: 75 mph Rear Impact Test

Test Date: 9/28/10

TARGET VEHICLE INFORMATION

Manufacturer	Ford Motor Company
Model	Explorer
Body Style	4DR SUV
Vehicle No.	2
VIN	1FMZU34X0WUA30455
Color	Red
Delivery Date	
Odometer Reading	156,357
Dealer	Capital Auto Auctions
Transmission	Automatic
Final Drive	4WD
Number of Cylinders	6
Engine Displacement (L)	4.0
Engine Placement	Longitudinal

TEST VEHICLE OPTIONS

Driver Airbag	Y
Passenger Airbag	Y
Anti-theft System	Y
Cruise Control	Y
Power Windows	Y
Power Steering	Y
Power Door Locks	Y
Tilt Wheel	Y
Air Conditioning	Y
Power Brakes	Y
Disc Brakes, Front	Y
Disc Brakes, Rear	Drum
Anti-lock Brakes	Y
AM / FM / Cassette	Y

DATA FROM CERTIFICATION LABEL

Manufactured By	Ford Motor Company	GVWR (kg)	2422 kg
Date of Manufacture	9/97	GAWR Front (kg)	1229 kg
		GAWR Rear (lkg)	1338 kg

DATA FROM TIRE PLACARD

Measured Parameter		
Maximum Tire Pressure (psi)		
Cold Pressure (psi)	26 psi	26 psi
Recommended Tire Size	P235/75R15	P235/75R15
Tire Size On Vehicle		
Tire Manufacturer		

Measured Parameter	Front	Rear	Third	Total
Type of Seats	Bucket	Bench	NA	
Number of Occupants	2	3	NA	5
Capacity Wt. (VCW) (kg)				
Cargo Wt. (RCLW) (kg)				

DATA SHEET NO. 12

GENERAL TEST AND TARGET VEHICLE PARAMETER DATA

Target Vehicle: 1998 Ford Explorer

Test Program: 75 mph Rear Impact Test

Test Date: 9/28/10

TARGET VEHICLE WEIGHTS

	Units	As Delivered (UVW) (Axle)			As Tested (ATW) (Axle)		
		Front	Rear	Total	Front	Rear	Total
Left	kg	524.5	417.5	942.0	563.5	465.0	1028.5
Right	kg	461.5	414.5	876.0	480.0	442.5	922.5
Ratio	%	54%	46%	-	53%	47%	-
Totals	kg	986.0	832.0	1818.0	1043.5	907.5	1951.0

TARGET VEHICLE TARGET TEST WEIGHT CALCULATION

Measured Parameter	Units	Value
Total Delivered Weight	kg	1818.0
Weight of 1 P572E ATD	kg	79.50
Rated Cargo / Luggage Weight (RCLW)	kg	-
Calculated Vehicle Target Weight (TVTW)	kg	1897.5

TARGET VEHICLE ATTITUDES

	Units	LF	RF	LR	RR
As Delivered	mm				
As Tested	mm	850	850	833	833
Post Test	mm	868	837	900	870

Weight of Ballast: _____

Vehicle Components Removed: oil, transmission fluid, antifreeze, gas, center Console

Weight Removed: 41.0 kg

Added: battery box, data acquisition, brake system, dummy, water in gas tank (75%), data acquisition for dummy, battery

Weight Added: 174 kg

DATA SHEET NO. 13

TARGET VEHICLE TIRE INFORMATION

Target Vehicle: 1998 Ford Explorer

Test Program: 75 mph Rear Impact Test

Test Date: 9/28/10

Vehicle Year		Vehicle Make	
VIN		Vehicle Model	

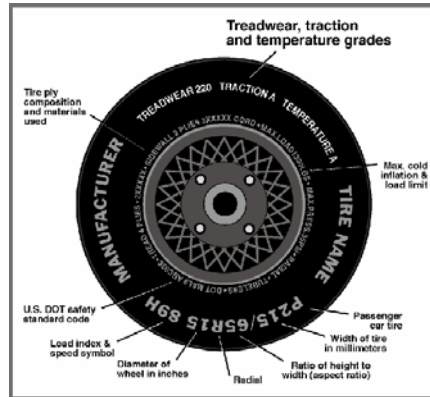

	Left Front	Right Front
Tire Manufacturer	Uniroyal	Goodyear
Tire Name	Laredo	Wrangler MTS
Tire Type	Radial	Radial
Tire Width (mm)	LT235	P235
Ratio of Height to Width (aspect ratio)	75	75
Radial	R	R
Wheel Diameter	15	15
Load Index & Speed Symbol	Load Range C	
Treadwear		340
Traction Grade		A
Temperature Grade		B
	Left Rear	Right Rear
Tire Manufacturer	Futura	Goodyear
Tire Name	Scrambler AP	Wrangler MTS
Tire Type	Radial	Radial
Tire Width (mm)	P235	P235
Ratio of Height to Width (aspect ratio)	75	75
Radial	R	R
Wheel Diameter	15	15
Load Index & Speed Symbol		
Treadwear	400	340
Traction Grade	A	A
Temperature Grade	B	B

DATA SHEET NO. 14

TARGET VEHICLE SEAT INFORMATION

Target Vehicle: 1998 Ford Explorer

Test Program: 75 mph Rear Impact Test

Test Date: 9/28/10

NORMAL DESIGN RIDING POSITION

Driver Seat Back Angle: 15 deg

Passenger Seat Back Angle: deg

(90 deg full up / 60 deg full down)

SEAT FORE / AFT POSITION

The driver and passenger seats are operated:
(manually / **electrically**)

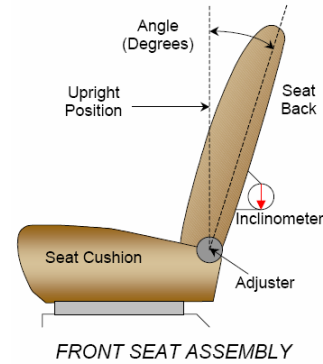

Driver Seat Fore / Aft Total Travel: 254 positions / **mm**

Passenger Seat Fore / Aft Total Travel: _____ positions / **mm**

As Tested:

Driver Seat Fore / Aft Position: 127 mm rearward of full forward

Passenger Seat Fore / Aft Position: _____

SEAT BELT UPPER ANCHORAGE

The seat belt anchorages were placed in 2 position of 4 with the top position as one.

or No Adjustment Available

SEAT HEIGHT ADJUSTMENT

Seat is positioned at its lowest setting

NOTES: _____

DATA SHEET NO. 14... (continued)

TARGET VEHICLE INFORMATION

Target Vehicle: 1998 Ford Explorer

Test Program: 75 mph Rear Impact Test

Test Date: 9/28/10

STEERING COLUMN ADJUSTMENT

The steering column was placed in the mid position of travel.

Pos.	Desc	Angle
3	Full Up	<u>65 deg</u>
2	Center	<u>72.5 deg</u>
1	Full Down	<u>80 deg</u>

As Tested 75 deg

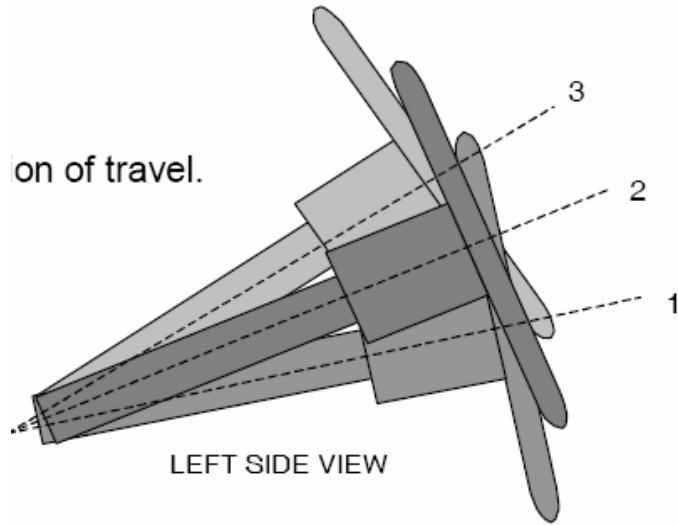

STEERING COLUMN ASSEMBLY

DATA SHEET NO. 15

TARGET VEHICLE DUMMY POSITIONING IN VEHICLE

Target Vehicle: 1998 Ford Explorer

Test Program: 75 mph Rear Impact Test

Test Date: 9/28/10

DUMMY MEASUREMENTS FOR FRONT SEAT OCCUPANTS

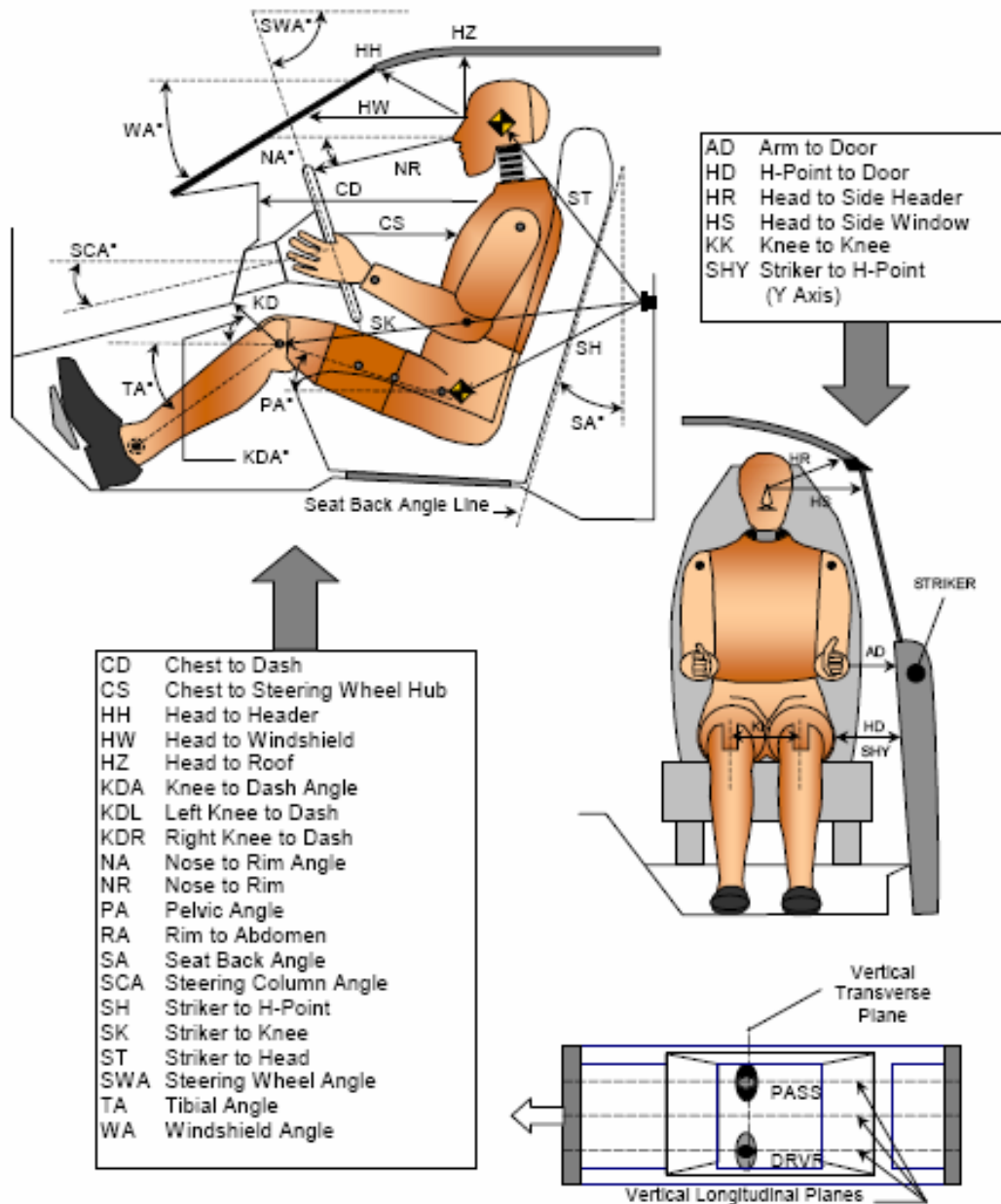

DATA SHEET NO. 15...(continued)

TARGET VEHICLE DUMMY POSITIONING IN VEHICLE

Target Vehicle: 1998 Ford Explorer

Test Program: 75 mph Rear Impact Test

Test Date: 9/28/10

Code	Measurement Description	Driver		Passenger	
		Length (mm)	Angle (°)	Length (mm)	Angle (°)
WA	Windshield Angle		38		
SWA	Steering Wheel Angle		70		
SCA	Steering Column Angle		25		
SA	Seat Back Angle (head rest post)		15		
HZ	Head to Roof (Z)	242			
HH	Head to Header	360			
HW	Head to Windshield	560			
HR	Head to Side Header (Y)	280			
NR	Nose to Rim	365			
CD	Chest to Dash	680			
CS	Chest to Steering Hub	260			
RA	Rim to Abdomen	n/a			
KDL	Left Knee to Dash	135			
KDR	Right Knee to Dash	135			
PA	Pelvic Angle		26		
TA	Tibia Angle	n/a			
KK	Knee to Knee (Y)	170			
SK	Striker to Knee	n/a			
ST	Striker to Head	n/a			
SH	Striker to H-Point	n/a			
SHY	Striker to H-Point (Y)	n/a			
HS	Head to Side Window	370			
HD	H-Point to Door	145			
AD	Arm to Door (Y)	90			
AA	Ankle to Ankle	250			

DATA SHEET NO. 16

TARGET VEHICLE SEAT BELT POSITIONING DATA

Target Vehicle: 1998 Ford Explorer

Test Program: 75 mph Rear Impact Test

Test Date: 9/28/10

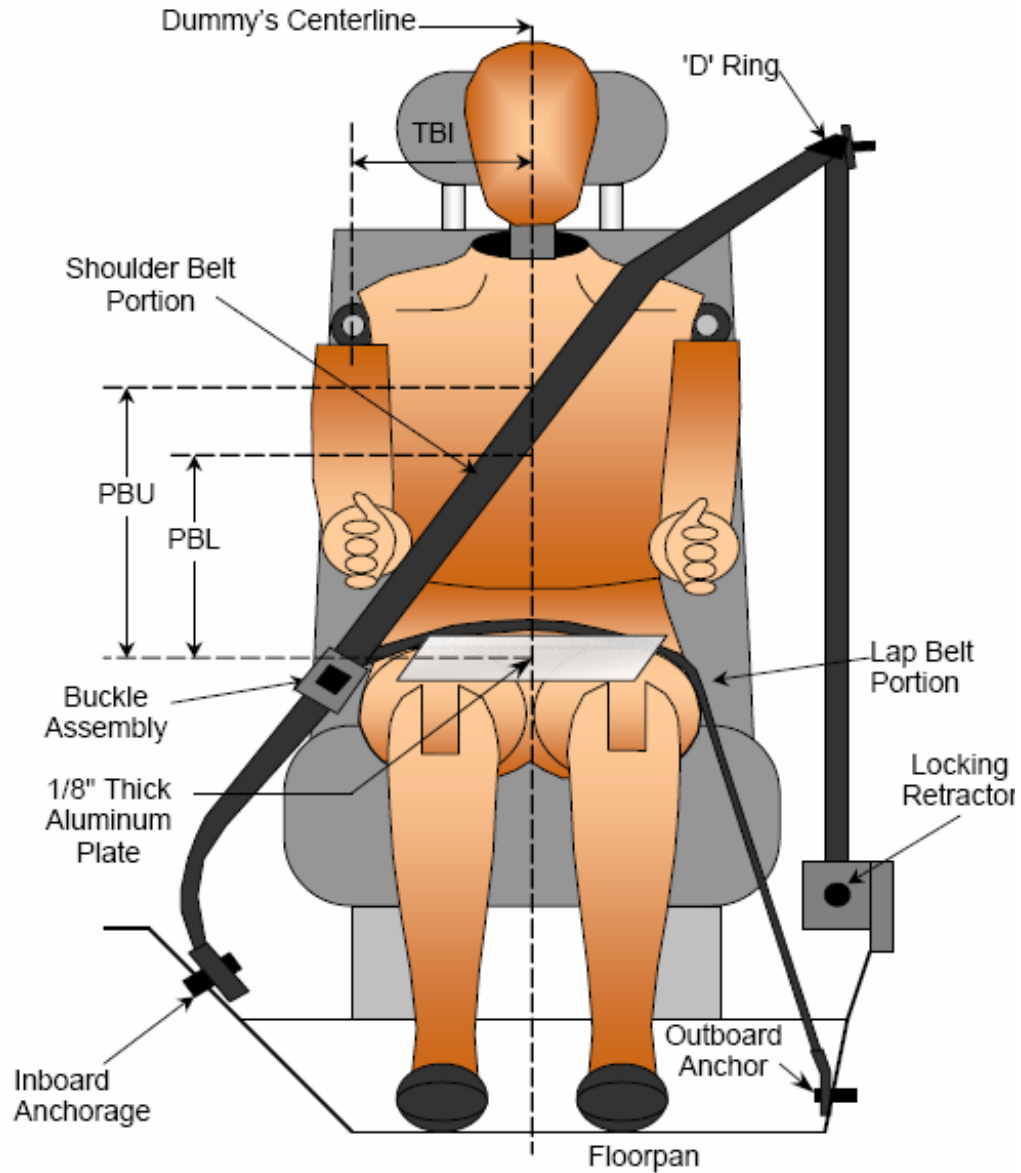

SEAT BELT POSITIONING MEASUREMENTS

Measurement Description	Units	Driver	Passenger
PBU – Top surface of reference to belt upper edge	mm		
PBL – Top surface of reference to belt lower edge	mm		

DATA SHEET NO. 17

TARGET VEHICLE MEASUREMENTS

Target Vehicle: 1998 Ford Explorer

Test Program: 75 mph Rear Impact Test

Test Date: 9/28/10

No.	Measurement	Units	Pre-Test	Post-Test	Difference
1	Total length of vehicle at centerline	Mm	4801	4420	381
4	FSOV to leading edge of right door	Mm	1422	1422	0
5	FSOV to leading edge of left door	Mm	1435	1448	-13
6	FSOV to lower leading edge of right door	Mm	1473	1473	0
7	FSOV to lower leading edge of left door	Mm	1486	1486	0
8	FSOV to upper leading edge of right door	Mm	1435	1435	0
9	FSOV to upper leading edge of left door	Mm	1454	1448	6
	FSOV to trailing edge of right door	Mm	2438	2438	0
	FSOV to trailing edge of left door	Mm	2438	2438	0
10	FSOV to lower trailing edge of right door	Mm	2457	2464	-7
11	FSOV to lower trailing edge of left door	Mm	2464	2464	0
	FSOV to upper trailing edge of right door	Mm	2477	2477	1
	FSOV to upper trailing edge of left door	Mm	2483	2489	-6
	FSOV to trailing edge of rr door	Mm	3226	3226	0
	FSOV to trailing edge of lr door	Mm	3226	3239	-13
	FSOV to lower edge of rr door	Mm	3181	3175	6
	FSOV to lower edge of lr door	Mm	3200	3200	0
	FSOV to upper trailing edge of rr door	Mm	3416	3404	12
	FSOV to upper trailing edge of lr door	Mm	3416	3442	-26
12	FSOV to bottom of right 'A' pillar	Mm	1461	1448	13
13	FSOV to bottom of left 'A' pillar	Mm	1473	-	-
	FSOV to bottom of right 'B' pillar	Mm	2419	2413	6
	FSOV to bottom of left 'B' pillar	Mm	2426	2451	-25
	FSOV to bottom of right 'C' pillar	Mm	3175	3150	25
	FSOV to bottom of left 'C' pillar	Mm	3175	3175	0
16	FSOV to steering column	Mm	1880	1930	-50
17	Center of steering column to left 'A' pillar	Mm	330	-	-
18	Center of steering column to headlining	Mm	368	457	-89
19	FSOV to right side of rear bumper	Mm	4483	4102	381
20	FSOV to left side of rear bumper	Mm	4470	4229	241
C1	Crush Zone 1 at right side	Mm	4801	4420	381
C2	Crush Zone 2 at right side	Mm	1422	1422	0
C3	Crush Zone 3 at right side	Mm	1435	1448	-13
C4	Crush Zone 4 at left side	Mm	1473	1473	0
C5	Crush Zone 5 at left side	Mm	1486	1486	0
C6	Crush Zone 6 at left side	Mm	1435	1435	0

DATA SHEET NO. 17... (continued)

TARGET VEHICLE MEASUREMENTS

Target Vehicle: 1998 Ford Explorer

Test Program: 75 mph Rear Impact Test

Test Date: 9/28/10

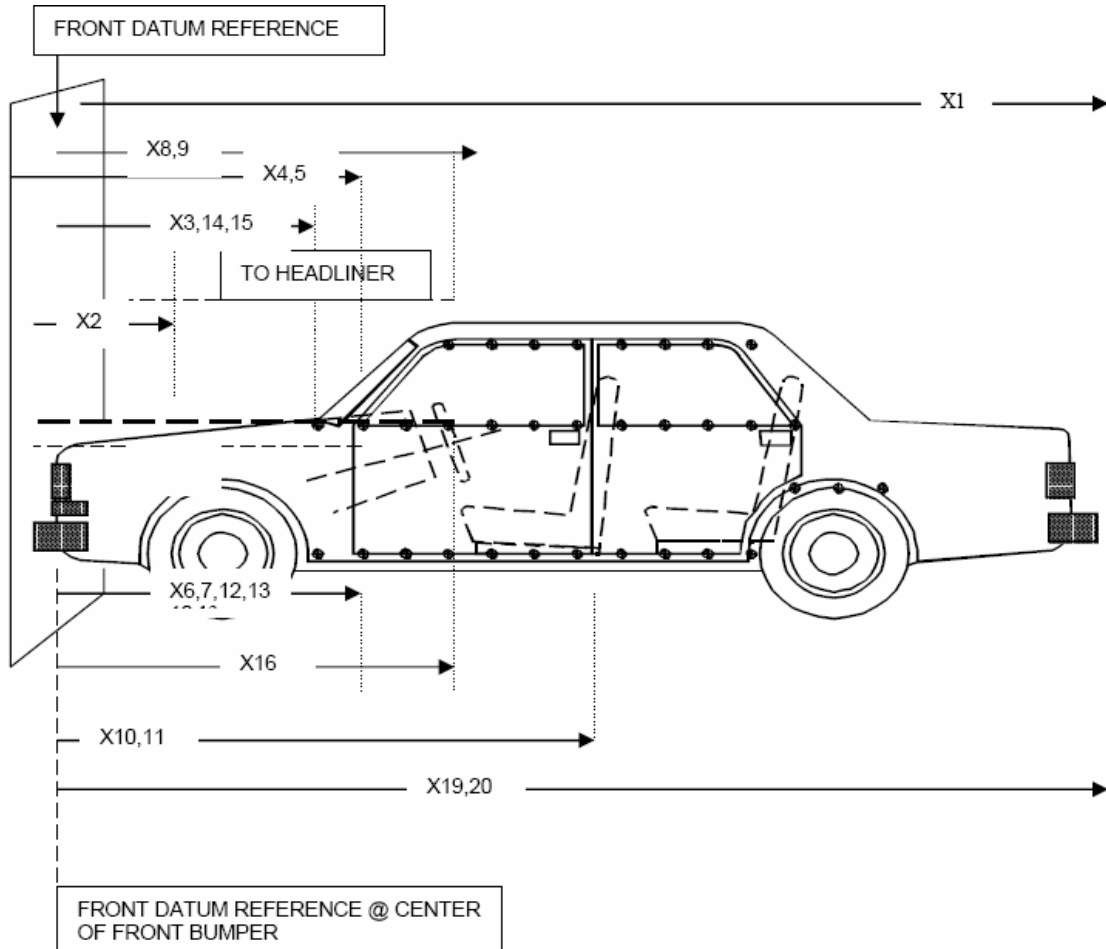

DATA SHEET NO. 17... (Continued)

TARGET VEHICLE MEASUREMENTS

Target Vehicle: 1998 Ford Explorer

Test Program: 75 mph Rear Impact Test

Test Date: 9/28/10

	Elements	Pre-Test (mm)
1	Total Length	4801
2	Total Width	1753
3	Rear Bumper Top Height	622
4	Rear Bumper Bottom Height	470
5	Longitudinal Member Top Height	635
6	Distance Between Longitudinal Members	991
7	Longitudinal Member Width	44
8	Engine Top Height	
9	Engine Bottom Height	
10	Engine and Gearbox Width	
11	Front Bumper – Engine Distance	
12	Front Shock Absorber Fixing Height	
13	Bonnet Leading Edge Height	
14	Front Shock Absorber Fixing Width	
15	Front Axle Location from FSOV	832
16	Rear Axle Location from FSOV	3638
17	Rear Bumper to Spare Tire	178
	C-Pillar – Rear Axle Distance	
	B-Pillar – C-Pillar Distance	
20	Roof Sill Bottom Height	1651
21	Roof Sill Top Height	1702
22	Floor Sill Bottom Height	305
23	Floor Sill Top Height	457

DATA SHEET NO. 18

TARGET VEHICLE ACCELEROMETER LOCATIONS & MEASUREMENTS

Target Vehicle: 1998 Ford Explorer

Test Program: 75 mph Rear Impact Test

Test Date: 9/28/10

Location	X (mm)	Y (mm)	Z (mm)
CG	2172	864	584

X Reference from the front bumper – positive towards the rear of the vehicle

Y Reference from the driver's side – positive towards the passenger's side of the vehicle

Z Reference from the ground – positive up

Description of Instrumentation Included:

DATA SHEET NO. 19

TARGET VEHICLE TARGET MEASUREMENTS

Target Vehicle: 1998 Ford Explorer

Test Program: 75 mph Rear Impact Test

Test Date: 9/28/10



Side Marker Measurements

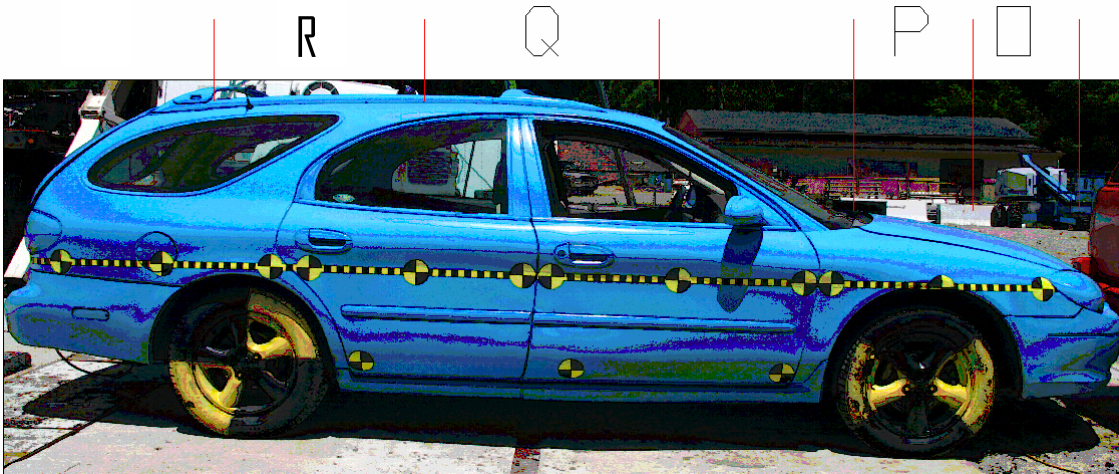

Top Marker Measurements

DATA SHEET NO. 19...Continued

TARGET VEHICLE PHOTOGRAPHIC REFERENCE TARGET LOCATIONS

Target Vehicle: 1998 Ford Explorer

Test Program: 75 mph Rear Impact Test

Test Date: 9/28/10

	Driver's Side Middle		Passenger's Side Middle	
	Pre	Post	Pre	Post
A	495	497	50	495
B	500	502	500	495
C	108	105	108	106
D	469	464	471	468
E	471	467	466	465
F	110	106	110	105
G	434	432	435	437
H	436	435	434	432
I	111	86	111	79
J	453	445	455	432
K	456	351	458	445
	Driver's Side Low		Passenger's Side Low	
L	440	440	443	441
M	443	440	443	443
	122	121	110	111
	320	318	320	321
	314	313	321	319
	Top			
	Pre		Post	
O	494		484	
P	485		492	
Q	1400		1140	
R	1401		1141	

DATA SHEET NO. 20

TARGET VEHICLE INTRUSION MEASUREMENTS

Target Vehicle: 1998 Ford Explorer

Test Program: 75 mph Rear Impact Test

Test Date: 9/28/10

DOOR OPENING WIDTH

Item	Description	Units	Pre-Test	Post-Test	Difference
A	Left Side Upper	mm	914	-	-
B	Left Side Lower	mm	889	-	-
D	Right Side Upper	mm	914	914	0
E	Right Side Lower	mm	889	892	-3
	Rear Left Side Upper	mm	813	803	10
	Rear Left Side Lower	mm	648	648	0
	Rear Right Side Upper	mm	813	789	24
	Rear Right Side Lower	mm	635	633	2

WHEELBASE MEASUREMENTS

Item	Description	Units	Pre-Test	Post-Test	Difference
C	Left Side Wheelbase	mm	2851	2858	7
F	Right Side Wheelbase	mm	2851	2578	-273

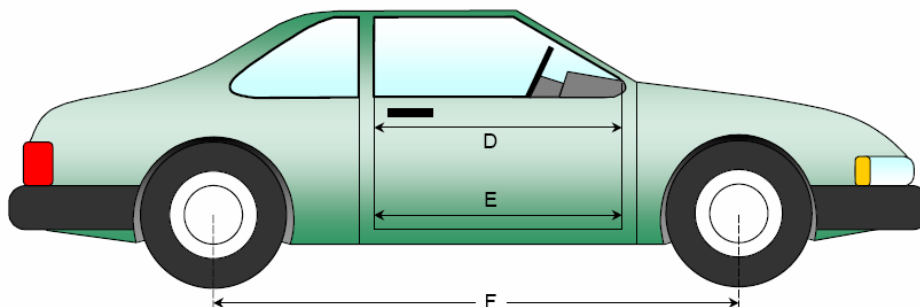
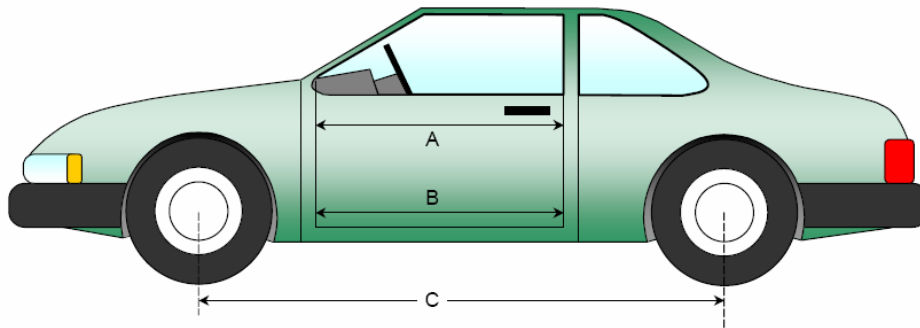

DATA SHEET NO. 21

TARGET VEHICLE ACCIDENT INVESTIGATION DIVISION DATA

Target Vehicle: 1998 Ford Explorer
Test Program: 75 mph Rear Impact Test Test Date: 9/28/10

VEHICLE INFORMATION

VIN: 1FMZU34X0WUA30455 Wheelbase (mm): 2851
Vehicle Size Category: _____ Test Weight (kg): 1951

ACCELEROMETER DATA

Accelerometer Locations: approximate c.g. location, see data page
Cal. Procedure / Interval: _____
Integration Algorithm: _____ Linearity: _____
Impact Velocity (kph): 0 kph
Velocity Change (kph): 52 kph Time of Separation (ms): 78

CRUSH PROFILE

Collision Deformation Classification: 06BDEW3 Midpoint of damage: 0
Damage Region Length (mm): 1549 Impact Mode: Rear

Measured at 610 mm from ground, mid bumper height

No.	Measurement Description	Units	Pre-Test	Post-Test	Difference
C1	Crush Zone 1 at left side	Mm	102,102	102,610	508
C2	Crush Zone 2 at left side	Mm	413,54	413,584	530
C3	Crush Zone 3 at left side	Mm	724,64	724,711	647
C4	Crush Zone 4 at Right Side	Mm	1035,64	1035,660	596
C5	Crush Zone 5 at Right Side	Mm	1346,54	1346,686	632
C6	Crush Zone 6 at Right Side	Mm	1651,102	1651,737	635
L	C1 to C6	Mm	1549	-	-

Measured at 660 mm from ground, top of bumper / bottom of lift gate

No.	Measurement Description	Units	Pre-Test	Post-Test	Difference
C1	Crush Zone 1 at left side	Mm	102,238	102,559	321
C2	Crush Zone 2 at left side	Mm	413,191	413,559	368
C3	Crush Zone 3 at left side	Mm	724,171	724,533	362
C4	Crush Zone 4 at Right Side	Mm	1035,171	1035,533	362
C5	Crush Zone 5 at Right Side	Mm	1346,191	1346,584	393
C6	Crush Zone 6 at Right Side	Mm	1651,244	1651,584	340
L	C1 to C6	Mm	1549	-	-