

GAME-CHANGING LIGHTWEIGHT E-MOTOR DESIGN ENABLES UNRIVALLED IN-WHEEL DRIVES

R. Kasper, Otto-von-Guericke University Magdeburg, Germany



Agenda



Introduction

- Mobility demands on e-motors
- State of the art

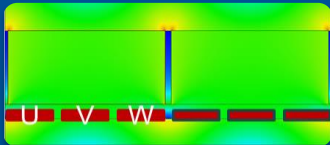

Lightweight motor design using **air-gap** winding

- Design principle
- Applications

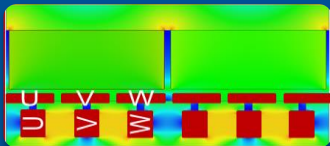

Improved motor design using **combined** winding

- Design principle
- Actual state

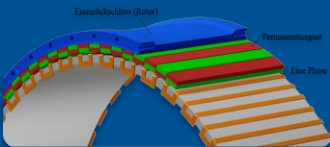

Summary and outlook

- Next steps
- Applications

Opportunities for Compact and Lightweight Wheel-Hub Motors

ujet



Yamaha



Toyota i-TRIL



Toyota e-Palette



Rinspeed



Honda



State of the Art - E-Motor Design

Application requirements

- Compact
- Low weight
- Low cost

- High power
- Efficient

- Scalable size
- Adaptable



Existing designs

- Permanent magnets for high power
- Bulky coils to lead current and to build magnetic field
➔ copper

- Slotted stator back-iron to carry coils and lead magnetic field
➔ iron

- Sums up to weight, cost and losses

Features Slotless Air-gap Winding

Basic

- Low weight
- No cogging torque
- Very compact

Additional

- High torque
- Excellent cooling
- High power
- Metal formed winding technology
 - High fill factor ➔ low losses
 - Low cost

State of the Art PMSM

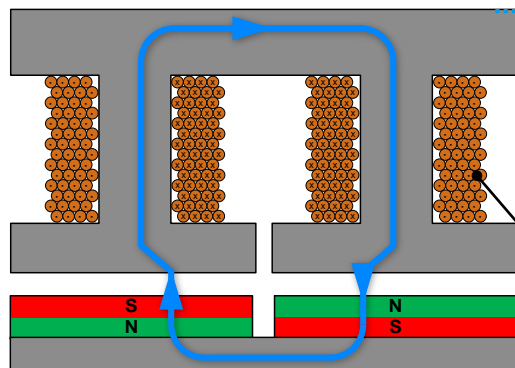

Air-gap winding

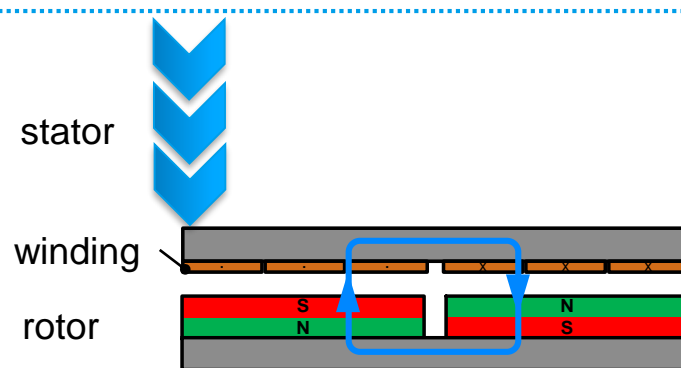

Magnetic Circuit Air-gap Winding

Compact magnetic circuit

- High B field in air-gap + axial wires
 - ➔ high torque by Lorentz force
- Extremely thin stator back-iron without saturation
 - ➔ low weight
 - ➔ small iron losses
- Low need of copper for winding
 - ➔ low weight
 - ➔ low cost

ANSYS magnetic field simulation for 0.5 mm air-gap

- Single wires in phase to avoid eddy currents

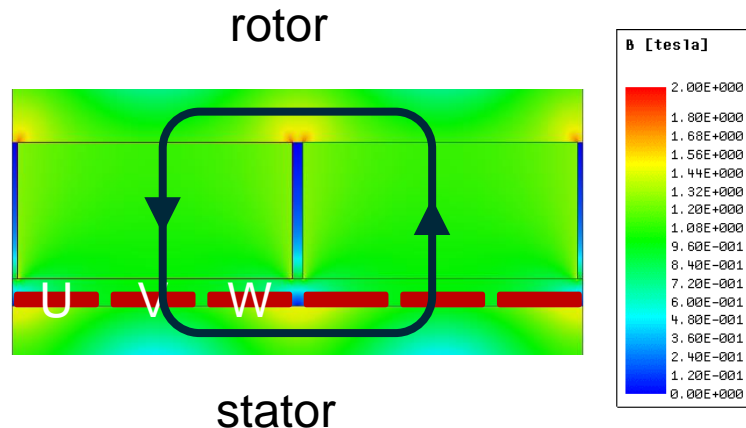

Patented Design Slotless Air-gap Winding

DE 10 2011 111 352 A1, WO 2013/029579 A2, US 20140217846 A1, CN 103931085 A, EP 2751906 A2

Meandering multi wire air-gap winding attached on stator back-iron

- Simple slotless ring geometry
- Flexible adaptable design
- Applicable to all motors and generators with external rotor
 - ➔ automated winding technology available
- Internal rotor machines possible
 - ➔ improved winding technology under development

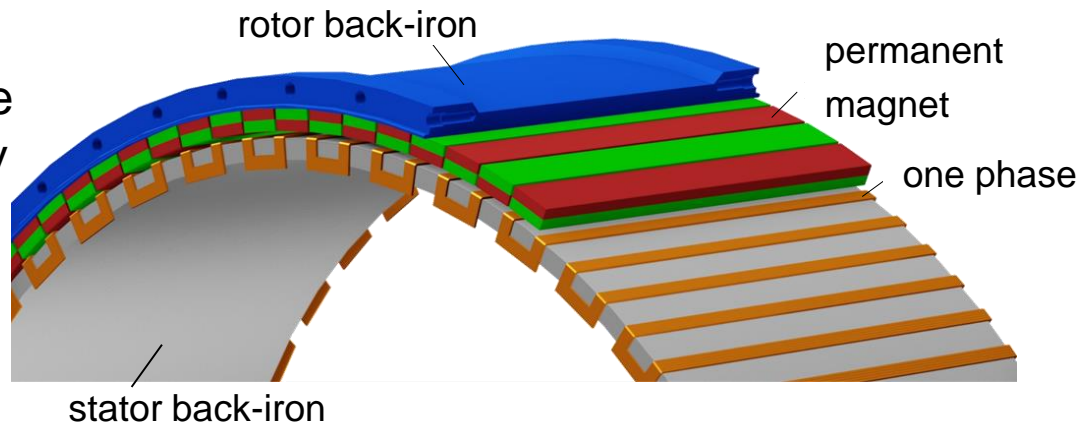

Prototype Design Electric Power Wheel EPW I

Integrated into 15" rim

- \varnothing app. 300 mm, width 100 mm
- Weight 20 kg
- Nominal
 - torque 300 Nm
 - speed 1350 rpm
 - voltage 400 V
 - power 40 kW \rightarrow 2 kW/kg
- Max. efficiency ≥ 93 %
- Excellent cooling

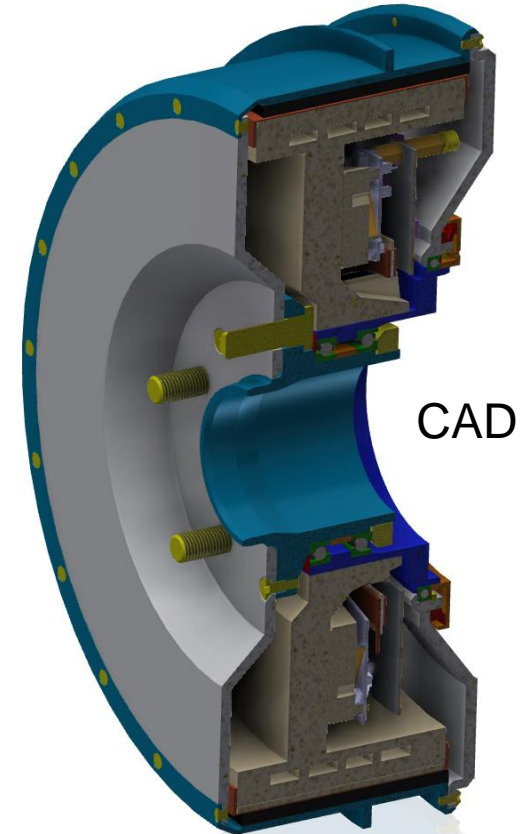
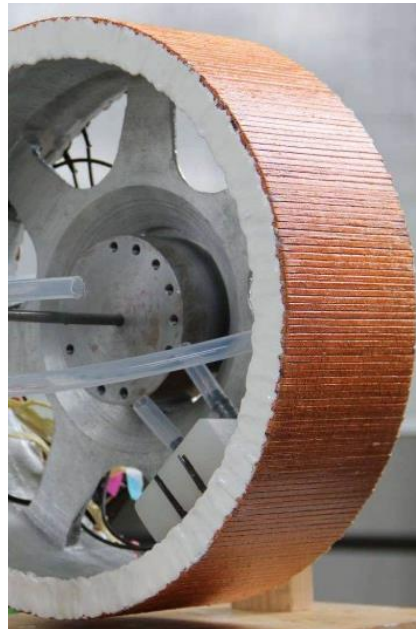

Prototype EPW I Test

General results

- DC Motor behavior
- Constant torque for all speed
- No weakening of B-field

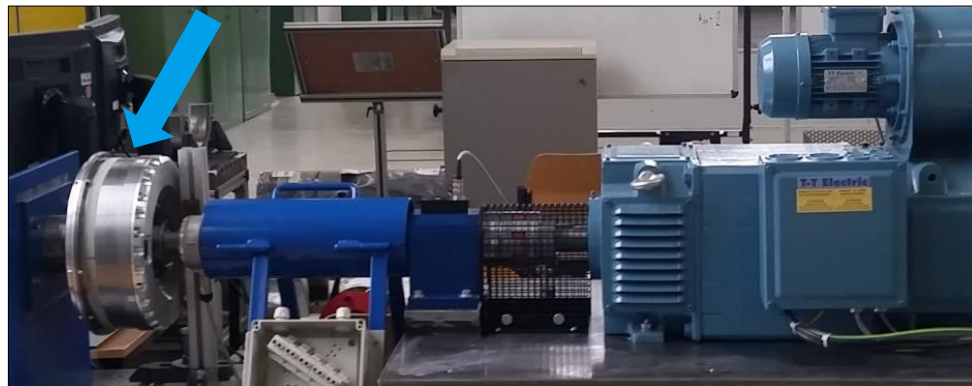
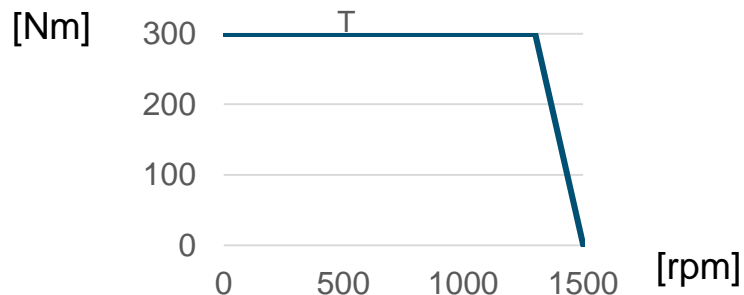





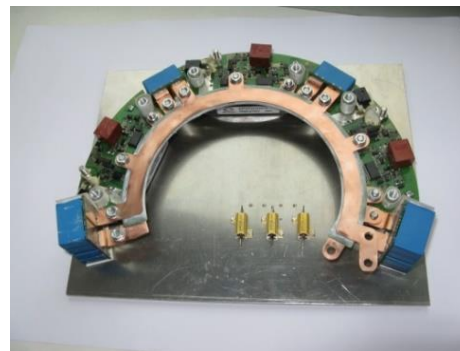

Integrated electrical control unit

- Small phase inductance $10 \mu\text{H}$
- Complex 2-stage electronic control



Competition Wheel-Hub-Motor EPW I

						
	<i>General Motors</i>	<i>Schaeffler AG</i>	<i>Siemens AG</i>	<i>Fraunhofer</i>	<i>Protean Electric</i>	<i>EPW I</i>
Rim Size [inch]	17	16	17	17	18	15
Weight [kg]	30	53	50	42	34	20
Power [kW]	16	33	63	55	54	40
Power/Weight [kW/kg]	0.53	0.62	1.26	1.31	1.59	2

Air-gap Winding Applications I

E-Scooter

- Power 4.5 kW
- Speed 500 rpm
- Torque 85 Nm
- Extreme lightweight construction
 - Scooter total: 32 kg
 - Motor: 2.7 kg
- Driving test successful (spring 2016)



ePower Wheel-Generator Trailer

- Recuperation power 30 kW
- Speed 350 rpm
- Air-cooled
- IAA commercial vehicles Hannover 2016 (2. award)
- Test stand evaluation successful (fall 2016)



Air-gap Winding Applications II

E-Motorcycle

- Integration into existing engine block/gearbox
- Power 12 kW
- Speed 6000 rpm
- Weight app. 8 kg
- Integrated water cooling system
- Design study (2017)

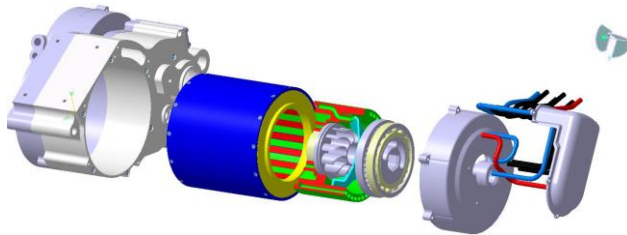

E-Flyboat

- High efficiency
- Low weight
- Power 2 x 5.5 kW
- Integration into hull
- Speed 600 to 2600 rpm
- Weight app. 8 kg
- Prototype (spring 2018)

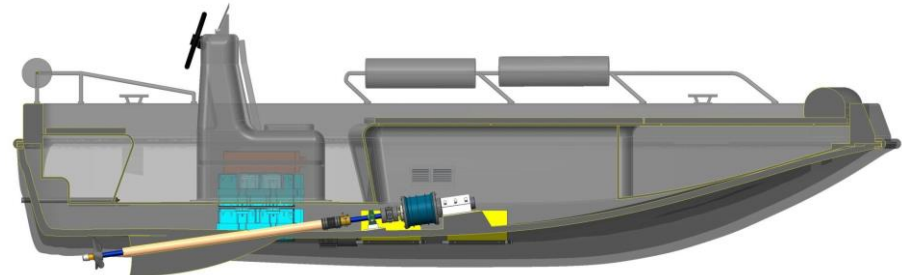

Air-gap Winding Applications III

E-Longboard

- Integration into standard axle
- Usable for any kind of rack
- Power 250 W
- Speed 2500 rpm
- Range 12 km

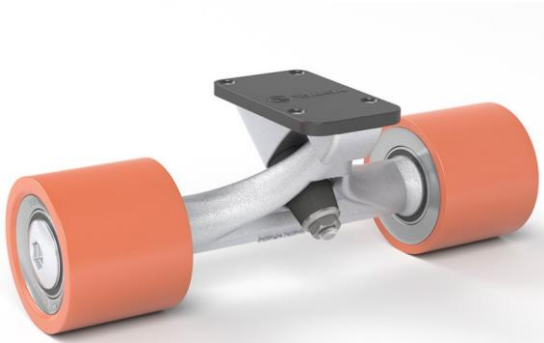

Darrieus Windmill Generator

- Integration into tower
- Power 2.75 kW
- Speed 180 rpm
- Ø 350 mm
- Length 100 mm

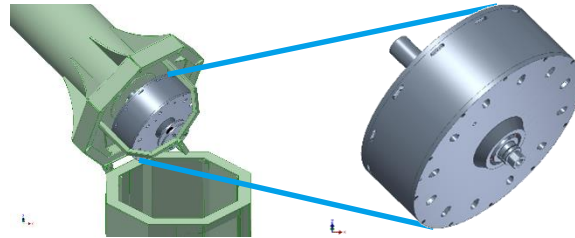

COMO Test Vehicle with EPW I

Electrified Smart (400V, 150 km)



Integrated Wheel-Hub-Motors

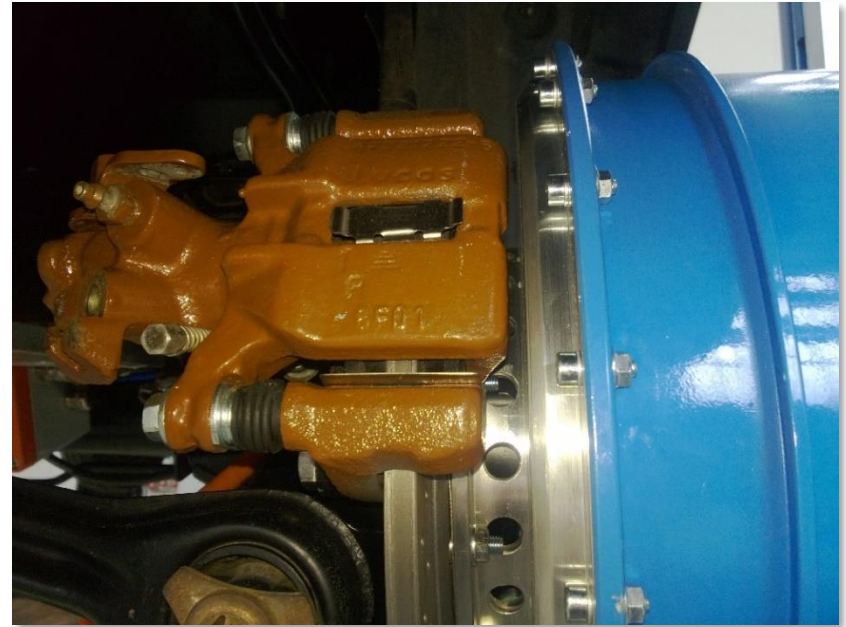

➔ Need for torque

Features Combined Winding

State of the Art PMSM

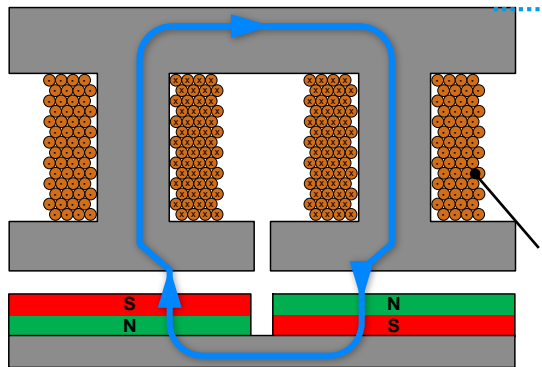

Air-gap winding

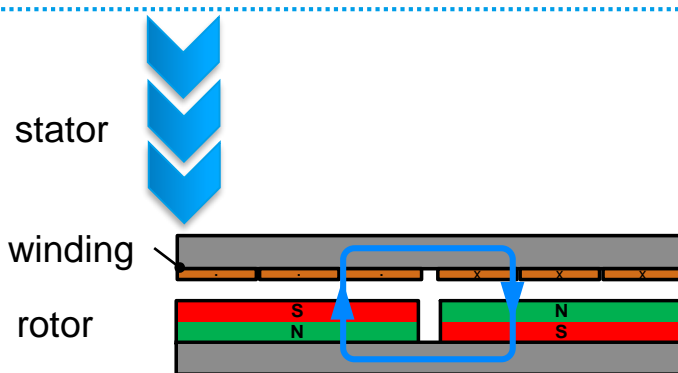

Combined winding

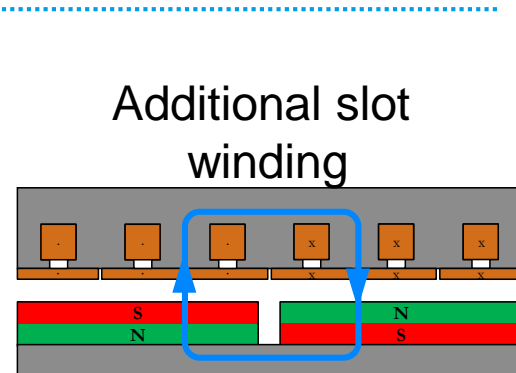

All advantages of air-gap winding + **Nearly double power and torque**

- Windings share permanent magnet field → re-use of magnets
- Windings do not interfere besides adding torque and emf

Magnetic Circuit Combined Winding

Compact magnetic circuit

- 2 windings working together
 - ➔ approx. double torque
- Only slightly higher stator back-iron
 - ➔ low weight
 - ➔ small iron losses
- Only slightly higher need for copper of slot winding
 - ➔ low weight
 - ➔ low cost

ANSYS magnetic field simulation for 0.5 mm air-gap

- 1 wire to maximize fill factor

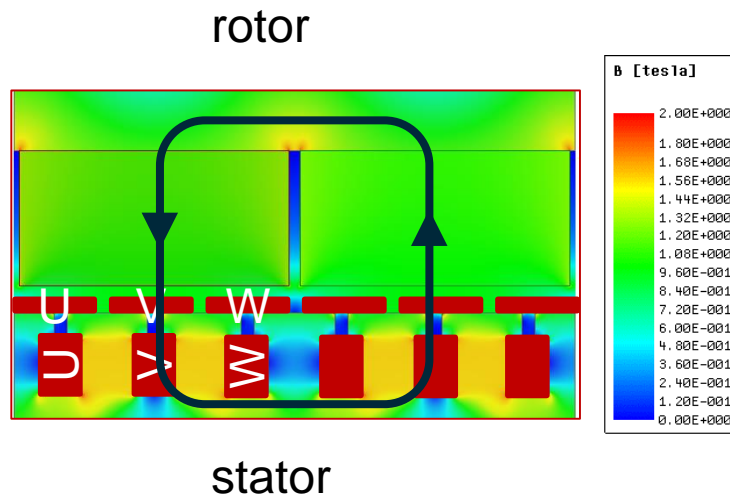

Meandering 1 wire slot winding in series to air-gap winding

- Simple weakly slotted ring geometry
- Adapted slot winding technology
 - High fill factor ➔ low losses
 - Low cost
- Customization of cogging torque and inductance by slot geometry
- Can use modified existing slot winding technology

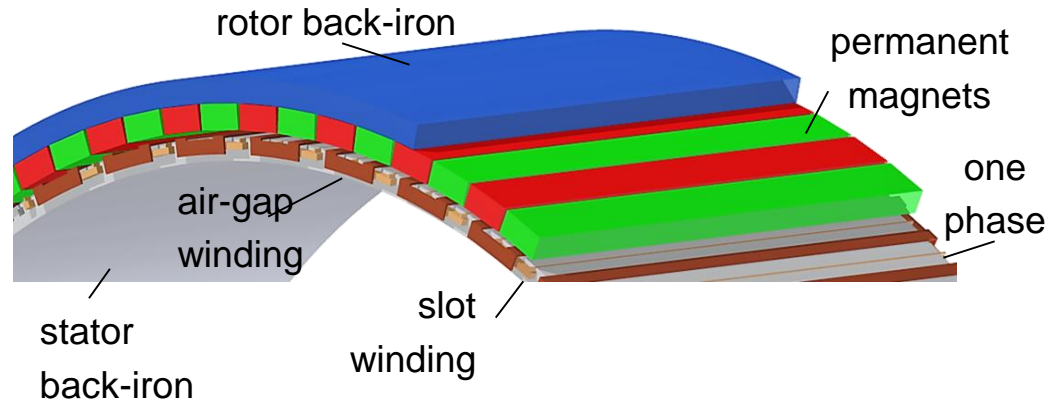

First Prototype EPW I → II

Design Parameters

- Extension of air-gap winding with slot winding using existing 15" EPW I prototype
- Torque 480 Nm
- Nominal power 62 kW
- Weight 21 kg
- Power/Weight ca. 3 kW/kg
- Max. efficiency $\geq 94\%$
- Completion February 2017

Stator

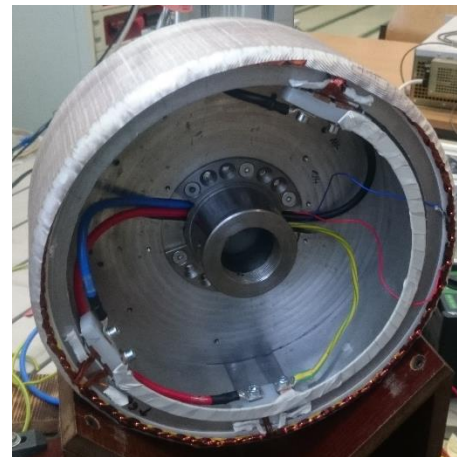

Winding Heads



Proof of Combined Winding Principle

Experimental Parameters EPW I → II

- Voltage (EMF) of combined winding sums up
- Torque of combined winding sums up
- No mutual interference of windings

➔ Proof of principle of combined winding

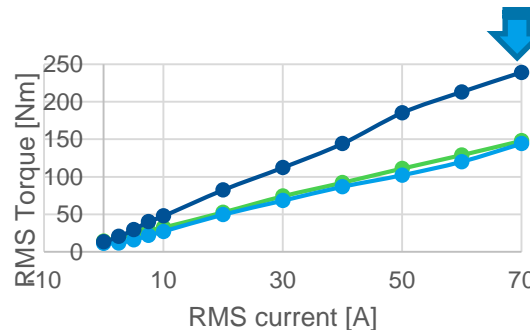
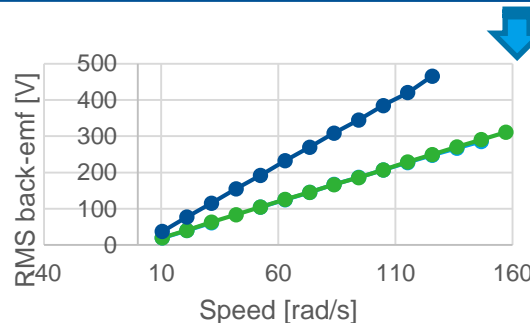

Limited by test equipment

● air-gap ● slot ● combined winding

Regular Prototype EPW II

Exploiting Full Potential of Combined Winding

Rim size 16 inch, width 100 mm

- Nominal
 - Torque 600 Nm
 - Power 64 kW
- Weight 16 kg
- Power/Weight 4 kW/kg
- Max. efficiency $\geq 95\%$
- Larger inductance ➔ standard FOC



Regular Prototype EPW II

Additional Features



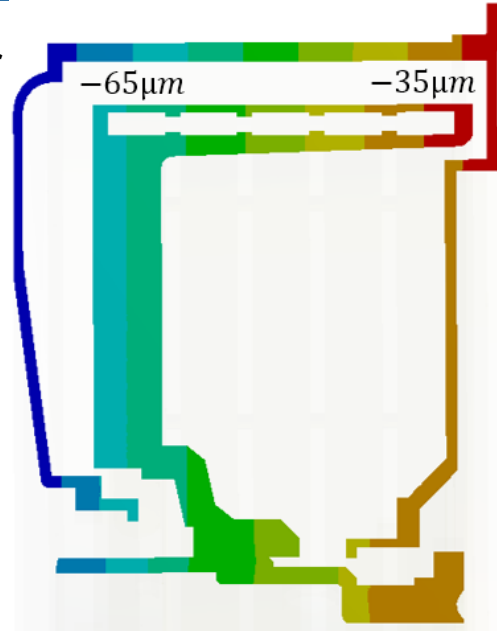

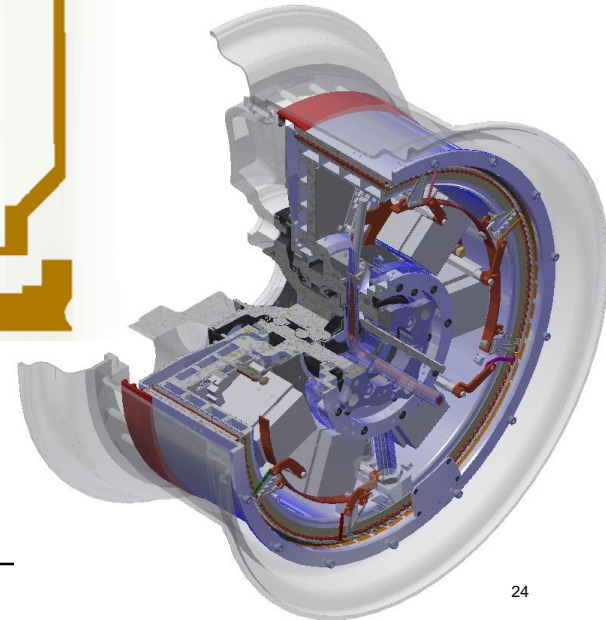

- New method of integration of motor into rim tolerating misuse of **15 kN** on rim
- Lightweight materials (BMW project LeiRaMo)
 - Al-foams
 - Carbon fibers
 - Hybrid = Al-foam + carbon
- Lightweight completely integrated power control unit



air-gap
reduction



Comparison Wheel-Hub-Motor EPW II

						
	<i>General Motors</i>	<i>Schaeffler AG</i>	<i>Siemens AG</i>	<i>Fraunhofer</i>	<i>Protean Electric</i>	<i>EPW II</i>
Rim Size [Zoll]	17	16	17	17	18	16
Weight [kg]	30	53	50	42	34	16
Power [kW]	16	33	63	55	54	64
Power/Weight [kW/kg]	0.53	0.62	1.26	1.31	1.59	4
Torque [Nm]	200	350	500	700	650	600
Torque/Weight [Nm/kg]	6.67	6.60	10	16.67	19.12	37.5

Paper # (if applicable)

Combined Winding Applications

Hybrid motor

- Power 90 kW
- Speed 7000 rpm
- Integration into gear
- Active weight app. 6 kg
- \varnothing reduction by 20%
- Simulation study for OEM



(picture similar)

Lightweight sports vehicle

- 4WD wheel hub motors EPW II
- Vehicle dynamics control
- Total vehicle weight 700 kg
- Unlimited range with range extender
- New project



(picture similar)

New motor technology

- Lightweight
- High power
- Compact
- Cost efficient
- Scalable

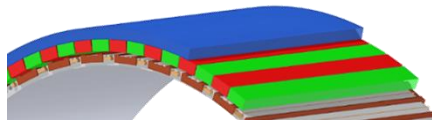

rim	13	16	19	21	23
T [Nm]	400	600	850	1000	1200

- Design environment

Air-gap winding offers

- Minimum iron/copper
- Small losses iron/copper
- Excellent cooling/overload
- Thin ring motor
- No cogging torque
- Automated winding application

Combined winding adds

- Double torque
- Best **power/** and **torque/weight**
- Compactness

Technology

- Optimization of production
 - of air-gap and slot winding
 - wound/stacked stator back-iron
- Improved architecture for higher power and torque

rim	13	16	19	21	23
T [Nm]	600	900	1275	1500	1800

+ 50%

Applications

- Automotive
 - Hybrid motor
 - Electric drive axle
 - Non-powertrain e-drives
- Non-automotive
 - Wind- and watermill generators
1-250 kW, 6-300 rpm
 - Pump motors 2-20 kW, 3000 rpm

Game-Changing Lightweight E-Motor Design Enables Unrivalled In-Wheel Drives

Thank you

Prof. Dr.-Ing. Roland Kasper
Otto-von-Guericke University Magdeburg
39106 Magdeburg, Germany
Am Universitaetsplatz 2
+49 391 675 8606
roland.kasper@ovgu.de