

EXPERIMENTAL TEST OF OCCUPANT ENTRAPMENT

**FORD TAURUS INTO REAR OF JEEP GRAND CHEROKEE
30% OFFSET, 50 MPH**

**PREPARED BY:
THE FEDERAL OUTDOOR IMPACT LABORATORY
6300 GEORGETOWN PIKE
MCLEAN, VA**

Test Date: July 1, 2010

Final Report Date: July 30, 2010

**PREPARED FOR:
U.S. DEPARTMENT OF TRANSPORTATION
FEDERAL HIGHWAY ADMINISTRATION
OFFICE OF SAFETY RESEARCH AND DEVELOPMENT
6300 GEORGETOWN PIKE
MCLEAN, VA**

SECTION 1

PURPOSE AND SUMMARY OF TEST

PURPOSE

The purpose of this 50 mph 30% offset rear impact test is to examine the occurrence of occupant entrapment in collisions similar in condition to that proposed for FMVSS 301.

SUMMARY

A 1995 Jeep Grand Cherokee was impacted in the rear by a 2000 Ford Taurus at a velocity of 50 mph. The Jeep and Ford were set so the right vertical edge of the front of the Ford would contact the Jeep rear 352.04 mm in right of the Jeep's longitudinal centerline. The test was performed at the Federal Outdoor Impact Laboratory on July 1, 2010. Pre- and Post-test photographs of the vehicle and dummy can be found in appendix A.

One real time camera and seven high-speed cameras were used to document the rear impact event. Camera locations and other pertinent camera information can be found in this report.

One 50th percentile male anthropomorphic test device (ATD) was placed in the driver seating position according to dummy placement instructions specified in the FMVSS 208 Laboratory Indicant Test Procedure.

The ATD was not instrumented for this test.

The 21 channels of data were recorded with an on-board data acquisition system. Appendix B contains the vehicle response data traces.

SECTION 2

OCCUPANT AND VEHICLE INFORMATION / DATA SHEETS

DATA SHEET NO. 1

BULLET VEHICLE CRASH TEST SUMMARY

Bullet Vehicle: 2000 Ford Taurus
Test Program: 50 MPH 70% 301 Rear Impact Test Date: 7/1/10

BULLET VEHICLE PRIMARY IMPACT DATA

Measured Parameter	Units	Value
Bullet Vehicle Velocity At Impact	kph	80
Bullet Vehicle Test Weight	kg	1,498
Bullet Vehicle Maximum Static Crush	mm	419
Impact Point	mm	NA

DOOR OPENING AND SEAT TRACK INFORMATION: BULLET VEHICLE

Description	Driver	Passenger
Front Door Opening	Functional after test	Functional after test
Rear Door Opening	Functional after test	Functional after test
Seat Track Shift (mm)	NA	NA
Seat Back Failure (deg)	NA	NA

TEST DUMMY INFORMATION: BULLET VEHICLE

Description	Driver	Passenger
Dummy Type	NA	NA
Head Contact	NA	NA
Chest Contact	NA	NA
Abdomen Contact	NA	NA
Left Knee Contact	NA	NA
Right Knee Contact	NA	NA

VIDEO COVERAGE

High Speed	7
Real Time	2
Total	9

Driver ATD Sensors	NA
Passenger ATD Sensors	NA
Bullet Vehicle Structure Accelerometers	9
Target Vehicle Structure Accelerometers	12
Total	21

DATA SHEET NO. 2

GENERAL TEST AND BULLET VEHICLE PARAMETER DATA

Bullet Vehicle: 2000 Ford Taurus
 Test Program: 50 MPH 70% 301 Rear Impact Test Date: 7/1/10

BULLET VEHICLE INFORMATION

Manufacturer	Ford
Model	Taurus
Body Style	Wagon
Vehicle No.	1
VIN	1FAFP58S0YA254876
Color	Painted Blue
Delivery Date	June 21, 2010
Odometer Reading	150,525
Dealer	Capitol Auto Auctions
Transmission	Automatic
Final Drive	Front
Number of Cylinders	6
Engine Displacement (L)	3.0
Engine Placement	Lateral

TEST VEHICLE OPTIONS

Driver Airbag	Y
Passenger Airbag	Y
Anti-theft System	
Cruise Control	Y
Power Windows	Y
Power Steering	Y
Power Door Locks	Y
Tilt Wheel	Y
Air Conditioning	Y
Power Brakes	Y
Disc Brakes, Front	Y
Disc Brakes, Rear	Y
Anti-lock Brakes	
AM / FM / Cassette	Y

DATA FROM CERTIFICATION LABEL

Manufactured By	Ford Motor Company	GVWR (kg)	2221
Date of Manufacture	06 / 00	GAWR Front (kg)	1123
		GAWR Rear (kg)	1098

DATA FROM TIRE PLACARD

Measured Parameter	Front	Rear
Maximum Tire Pressure (psi)		
Cold Pressure (psi)	30	30
Recommended Tire Size	P215/60TR16	P215/60TR16
Tire Size On Vehicle	P215/60R16	P215/60R16
Tire Manufacturer	Bridgestone / Goodyear	BF Goodrich

Measured Parameter	Front	Rear	Third	Total
Type of Seats	Bucket / Bench	Bench	Bench	
Number of Occupants	3	3	2	8
Capacity Wt. (VCW) (kg)				745
Cargo Wt. (RCLW) (kg)				201

DATA SHEET NO. 3

BULLET VEHICLE PARAMETER DATA

Bullet Vehicle: 2000 Ford Taurus
 Test Program: 50 MPH 70% 301 Rear Impact Test Date: 7/1/10

BULLET VEHICLE WEIGHTS

	Units	As Delivered (UVW) (Axle)			As Tested (ATW) (Axle)		
		Front	Rear	Total	Front	Rear	Total
Left	kg	457.5	297.5	755	445.0	321.0	766
Right	kg	451.5	269.5	721	434.5	297.5	732
Ratio	%	61.6%	38.4%		58.7%	41.3%	
Totals	kg	909	567	1476	879.5	618.5	1498

BULLET VEHICLE TARGET TEST WEIGHT CALCULATION

Measured Parameter	Units	Value
Total Delivered Weight	kg	1476
Weight of 1 P572E ATD	kg	NA
Rated Cargo / Luggage Weight (RCLW)	kg	NA
Calculated Vehicle Target Weight (TVTW)	kg	1476

BULLET VEHICLE ATTITUDES

	Units	LF	RF	LR	RR
As Delivered	mm				
As Tested	mm	724	740	705	718
Post Test	mm	686	762	705	724

Weight of Ballast: _____

Vehicle Components Removed: Spare tire, trunk trim removed for instrumentation

Weight Removed: 25 kg

Added: Data Acquisition, Battery Box, Instrument Tray, Brake System

Weight Added: 47 kg

DATA SHEET NO. 4

BULLET VEHICLE TIRE INFORMATION

Bullet Vehicle: 2000 Ford Taurus
 Test Program: 50 MPH 70% 301 Rear Impact Test Date: 7/1/10

Vehicle Year	2000	Vehicle Make	Ford
VIN	1FAFP58S0YA254876	Vehicle Model	Taurus

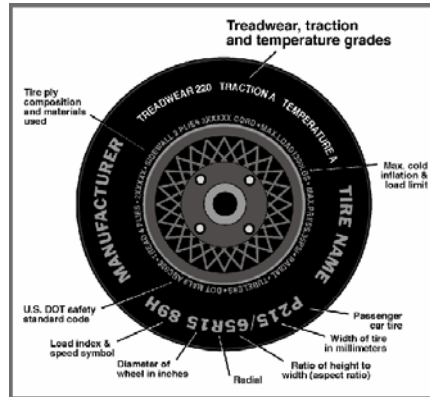

	Left Front	Right Front
Tire Manufacturer	Bridgestone	Goodyear
Tire Name	Insignia SE	Allegra
Tire Type	P	P
Tire Width (mm)	215	215
Ratio of Height to Width (aspect ratio)	60	60
Radial	R	R
Wheel Diameter	16	16
Load Index & Speed Symbol		
Treadwear	380	680
Traction Grade	B	A
Temperature Grade	B	B
	Left Rear	Right Rear
Tire Manufacturer	BF Goodrich	BF Goodrich
Tire Name	Touring T/A	Touring T/A
Tire Type	P	P
Tire Width (mm)	215	215
Ratio of Height to Width (aspect ratio)	60	60
Radial	R	R
Wheel Diameter	16	16
Load Index & Speed Symbol		
Treadwear	640	640
Traction Grade	A	A
Temperature Grade	B	B

DATA SHEET NO. 5

BULLET VEHICLE MEASUREMENTS

Bullet Vehicle: 2000 Ford Taurus

Test Program: 50 MPH 70% 301 Rear Impact

Test Date: 7/1/10

No.	Measurement	Units	Pre-Test	Post-Test	Diff
1	Total length of vehicle at centerline	mm	5029	4724.4	304.6
2	RSOV to front of engine	mm	4470	4368.8	101.2
3	RSOV to firewall centerline	mm	3916.5	3916.5	0
4	RSOV to leading edge of right door	mm	3524.3	3524.3	0
5	RSOV to leading edge of left door	mm	3524	3505.2	18.8
6	RSOV to lower leading edge of right door	mm	3435	3429	6
7	RSOV to lower leading edge of left door	mm	3435	3390.9	44.1
8	RSOV to upper leading edge of right door	mm	2886	2870.2	15.8
9	RSOV to upper leading edge of left door	mm	2908	2895.6	12.4
	RSOV to trailing edge of right door	mm	2416.4	2416.4	0
	RSOV to trailing edge of left door	mm	2413	2387.6	25.4
10	RSOV to lower trailing edge of right door	mm	2347.8	2347.8	0
11	RSOV to lower trailing edge of left door	mm	2369	2311.4	57.6
	RSOV to upper trailing edge of right door	mm	2311.6	2311.6	0
	RSOV to upper trailing edge of left door	mm	2311	2273.3	37.7
	RSOV to trailing edge of rear right door	mm	1372	1397	25
	RSOV to trailing edge of rear left door	mm	1363.6	1363.6	0
	RSOV to lower trailing edge of rear right door	mm	1670	1663.7	6.3
	RSOV to lower trailing edge of rear left door	mm	1676	1625.6	50.4
	RSOV to upper trailing edge of rear right door	mm	1568.3	1568.3	0
	RSOV to upper trailing edge of rear left door	mm	1549	1536.7	12.3
12	RSOV to bottom of right 'A' pillar	mm	3425.7	3425.7	0
13	RSOV to bottom of left 'A' pillar	mm	3428.9	3428.9	0
	RSOV to bottom of right 'B' pillar	mm	2385.9	2385.9	0
	RSOV to bottom of left 'B' pillar	mm	2387.5	2387.5	0
	RSOV to bottom of right 'C' pillar	mm	1657.4	1657.4	0
	RSOV to bottom of left 'C' pillar	mm	1657.4	1657.4	0
14	RSOV to firewall on right side	mm	3823	3581.4	241.6
15	RSOV to firewall on left side	mm	3874	3568.7	305.3
16	RSOV to steering column	mm	2985	2971.8	13.2
17	Center of steering column to left 'A' pillar	mm	301.4	301.4	0
18	Center of steering column to headlining	mm	432	432	0.2
19	RSOV to right side of front bumper	mm	4839	4724.4	114.6
20	RSOV to left side of front bumper	mm	4839	4826	13
21	Length of Engine Block	mm	559	559	0
RD	RSOV to right side of dash panel	mm	3108	3098.8	9.2
CD	RSOV to center of dash panel	mm			
LD	RSOV to left side of dash panel	mm	3121	3111.5	9.5

DATA SHEET NO. 5... (continued)

BULLET VEHICLE MEASUREMENTS

Bullet Vehicle:

2000 Ford Taurus

Test Program:

50 MPH 70% 301 Rear Impact

Test Date: 7/1/10

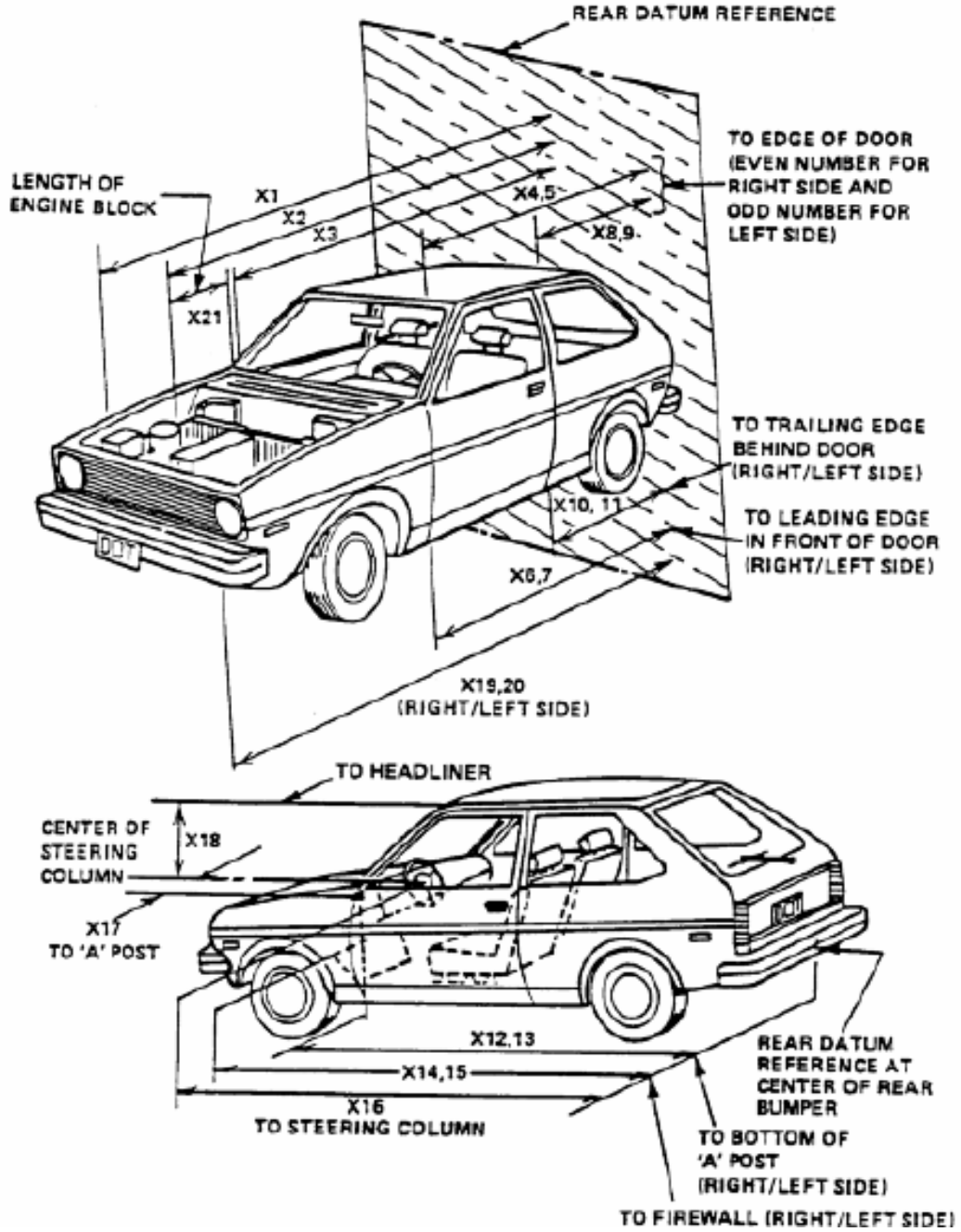

DATA SHEET NO. 5... (Continued)

BULLET VEHICLE MEASUREMENTS

Bullet Vehicle: 2000 Ford Taurus

Test Program: 50 MPH 70% 301 Rear Impact

Test Date: 7/1/10

	Elements	Measurement (mm)
1	Total Length	5029
2	Total Width	1778
3	Front Bumper Top Height	559
4	Front Bumper Bottom Height	279
5	Longitudinal Member Top Height	756
6	Distance Between Longitudinal Members	1372
7	Longitudinal Member Width	
8	Engine Top Height	787
9	Engine Bottom Height	
10	Engine and Gearbox Width	
11	Front Bumper – Engine Distance	330
12	Front Shock Absorber Fixing Height	889
13	Bonnet Leading Edge Height	737
14	Front Shock Absorber Fixing Width	1137
15	Front Bumper – Front Axle distance	1035
16	Front Axle – A Pillar Distance	540
17	A-Pillar – B-Pillar Distance	1080
18	C-Pillar – Rear Axle Distance	381
19	B-Pillar – C-Pillar Distance	781
20	Roof Sill Bottom Height	1226
21	Roof Sill Top Height	1372
22	Floor Sill Bottom Height	197
23	Floor Sill Top Height	362

DATA SHEET NO. 6

BULLET VEHICLE ACCELEROMETER LOCATIONS & MEASUREMENTS

Bullet Vehicle: 2000 Ford Taurus

Test Program: 50 MPH 70% 301 Rear Impact

Test Date: 7/1/10

Location	X (mm)	Y (mm)	Z (mm)
CG	2794	-25.4	-330.2

X Reference from the rear bumper – positive towards the front of the vehicle

Y Reference from the center line – positive towards the right side of the vehicle

Z Reference from the ground – positive down

Description of Instrumentation Included:

Triaxial accelerometer at cg, redundant triaxial accelerometer at cg, triaxial roll rate

sensor at cg.

DATA SHEET NO. 7

BULLET VEHICLE PHOTOGRAPHIC REFERENCE TARGET LOCATIONS

Bullet Vehicle: 2000 Ford Taurus

Test Program: 50 MPH 70% 301 Rear Impact

Test Date: 7/1/10

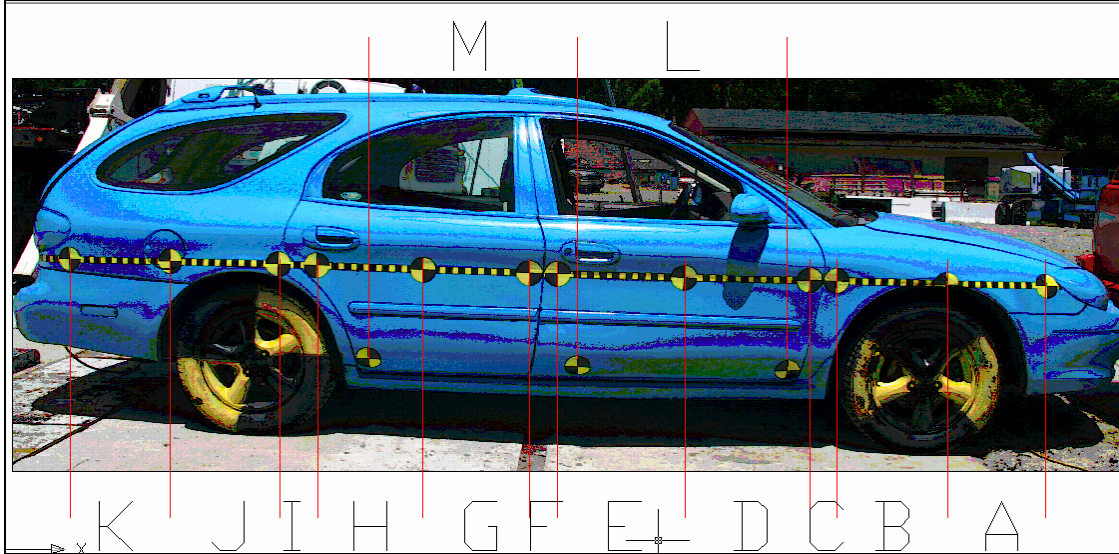

Side Marker Measurements

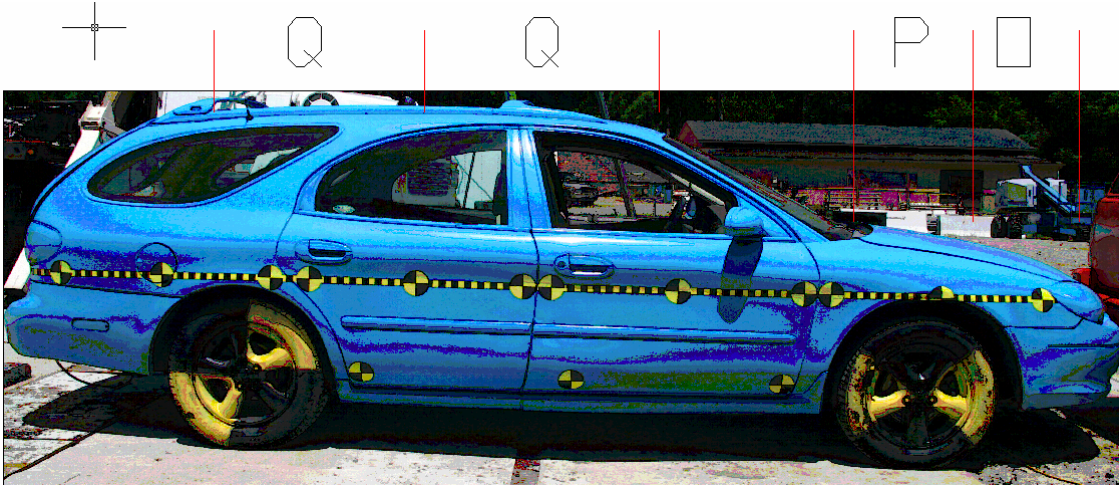

Top Marker Measurements

DATA SHEET NO. 7

BULLET VEHICLE PHOTOGRAPHIC REFERENCE TARGET LOCATIONS

Bullet Vehicle: 2000 Ford Taurus

Test Program: 50 MPH 70% 301 Rear Impact

Test Date: 7/1/10

	Driver's Side Middle		Passenger's Side Middle	
	Pre	Post	Pre	Post
A	440	440	440	440
B	438	434	437	440
C	54	112	108	108
D	497	500	502	498
E	495	498	524	496
F	102	106	105	114
G	419	434	431.8	422
H	425	433	433	427
I	156	148	146	155
J	460	451	451	460
K	457	458	457	460
	Driver's Side Low		Passenger's Side Low	
L	841	843	846	843
M	832	645	843	840
	Top			
	Pre		Post	
O	445		466	
P			467	
Q	1046		1047	
R	1033		1033	

DATA SHEET NO. 8

BULLET VEHICLE INTRUSION MEASUREMENTS

Bullet Vehicle: 2000 Ford Taurus

Test Program: 50 MPH 70% 301 Rear Impact

Test Date: 7/1/10

DOOR OPENING WIDTH

Item	Description	Units	Pre-Test	Post-Test	Difference
A	Left Side Upper	mm	973	973	0
B	Left Side Lower	mm	923.5	923.5	0
D	Right Side Upper	mm	962	962	0
E	Right Side Lower	mm	927	914	920.5
	Rear Left Side Upper	mm	927	927	0
	Rear Left Side Lower	mm	682.5	682.5	0
	Rear Right Side Upper	mm	927	914	13
	Rear Right Side Lower	mm	686	679	7

WHEELBASE MEASUREMENTS

Item	Description	Units	Pre-Test	Post-Test	Difference
C	Left Side Wheelbase	mm	2743	2807	-64
F	Right Side Wheelbase	mm	2737	2680	57

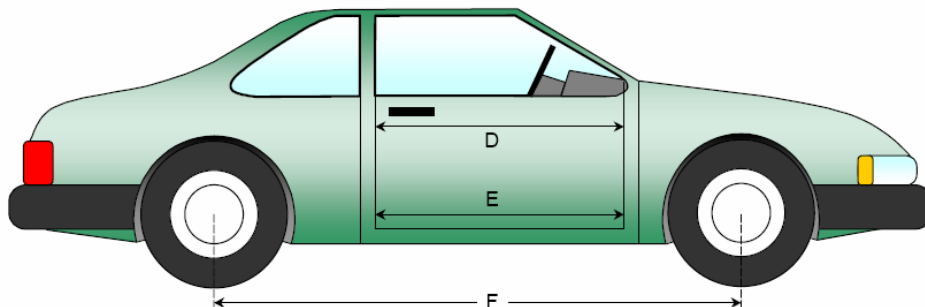
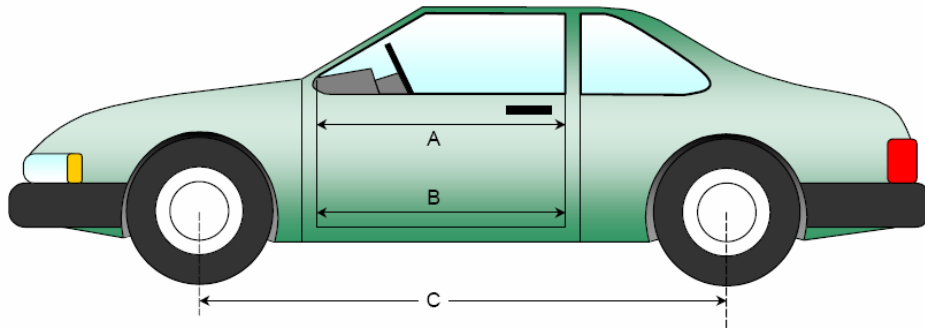

DATA SHEET NO. 9

BULLET VEHICLE INTRUSION MEASUREMENTS

Bullet Vehicle: 2000 Ford Taurus

Test Program: 50 MPH 70% 301 Rear Impact

Test Date: 7/1/10

DRIVER COMPARTMENT INTRUSION

Item	Description	Units	Pre-Test	Post-Test	Difference
AB	Door Opening (inside window jam)	mm	914	889	25
CX	Left Knee Bolster to X	mm	272.5	272.5	0
DX	Right Knee Bolster to X	mm	266.5	266.5	0
EX	Brake Pedal to X	mm	533	489	44
FX	Foot Rest to X	mm	511	511	0
GX	Center of Steering Column Wheel Hub to X	mm	0	0	0

X = Front of Seat Track (stationary)

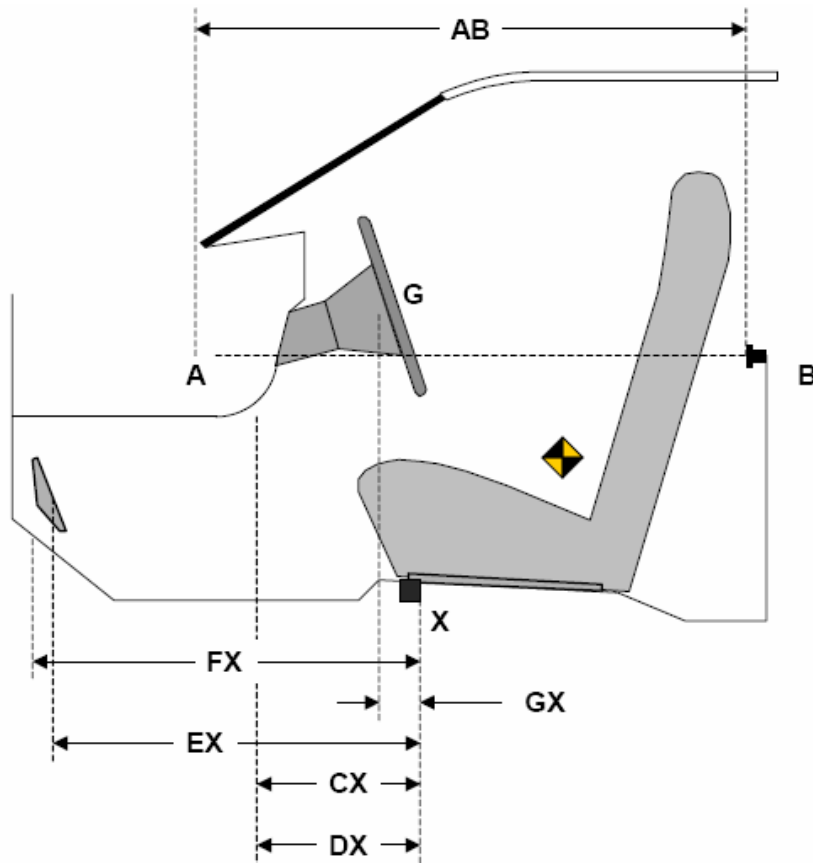

DRIVER COMPARTMENT

DATA SHEET NO. 9... (continued)
BULLETT VEHICLE INTRUSION MEASUREMENTS

Bullet Vehicle: 2000 Ford Taurus

Test Program: 50 MPH 70% 301 Rear Impact

Test Date: 7/1/10

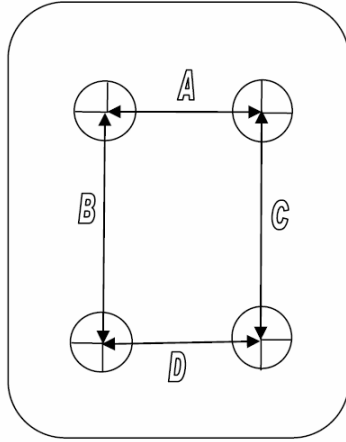

Driver

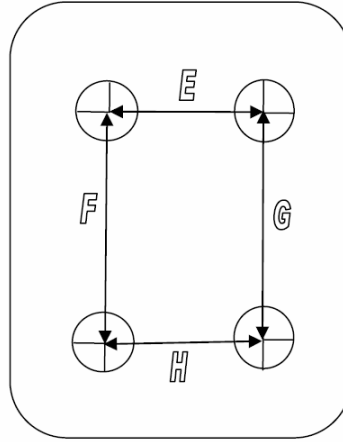

Passenger

Measurement	Pre-Test	Post Test	Difference
A			
B			
C			
D			
E			
F			
G			
H			

	Pre		Post	
	D	P	D	P
From Front of Seat to Firewall	737	673	737	648

DATA SHEET NO. 9

BULLET VEHICLE ACCIDENT INVESTIGATION DIVISION DATA

Bullet Vehicle: 2000 Ford Taurus
 Test Program: 50 MPH 70% 301 Rear Impact Test Date: 7/1/10

VEHICLE INFORMATION

VIN: 1FAFP58S0YA254876 Wheelbase (mm): 2740
 Vehicle Size Category: 3 Test Weight (kg): 1498

ACCELEROMETER DATA

Accelerometer Locations: at cg
 Cal. Procedure / Interval: _____
 Integration Algorithm: _____ Linearity: _____
 Impact Velocity (kph): 80 kph
 Velocity Change (kph): 52 kph Time of Separation (ms): 224

CRUSH PROFILE

Collision Deformation Classification: 12FWDE5 Midpoint of damage +267mm
 Damage Region Length (mm): 1245 mm Impact Mode: _____

At Bumper: z = 558.8 mm (y pos, x pos or crush)

No.	Measurement Description	Units	Pre-Test	Post-Test	Difference
C1	Crush Zone 1 at left side	mm	1612.9,191	1473.2, 190.5	+0.5
C2	Crush Zone 2 at left side	mm	1333.5,51	1219.2,215.9	-164.9
C3	Crush Zone 3 at left side	mm	1041.5,0	965.2, 304.8	-304.8
C4	Crush Zone 4 at Right Side	mm	749.3,0	711.2, 419.1	-419.1
C5	Crush Zone 5 at Right Side	mm	457.2,51	482.6, 330.2	-279.2
C6	Crush Zone 6 at Right Side	mm	165.1,191	228.6, 330.2	-139.2
L	C1 to C6	mm	1448	1244.6	

At top of radiator (under ride): z = 762 mm (y pos, x pos or crush)

No.	Measurement Description	Units	Pre-Test	Post-Test	Difference
C1	Crush Zone 1 at left side	mm		1612.9, 495.3	
C2	Crush Zone 2 at left side	mm		1333.5, 406.4	
C3	Crush Zone 3 at left side	mm		1041.4, 482.6	
C4	Crush Zone 4 at Right Side	mm		749.3, 546.1	
C5	Crush Zone 5 at Right Side	mm		457.2, 558.8	
C6	Crush Zone 6 at Right Side	mm		165.1, 673.1	
L	C1 to C6	mm		1448	

DATA SHEET NO. 10

TARGET VEHICLE CRASH TEST SUMMARY

Target Vehicle: 1995 Jeep Grand Cherokee
Test Program: 50 MPH 70% 301 Rear Impact Test Date: 7/1/10

TARGET VEHICLE PRIMARY IMPACT DATA

Measured Parameter	Units	Value
Target Vehicle Velocity At Impact	kph	0.0
Target Vehicle Test Weight	kg	1856.5
Target Vehicle Maximum Static Crush	mm	939.8
Impact Point	mm	NA

DOOR OPENING AND SEAT TRACK INFORMATION: TARGET VEHICLE

Description	Driver	Passenger
Front Door Opening	Crush locked	Functional After Test
Rear Door Opening	Crush Locked	Crush Locked
Seat Track Shift (mm)	TBD	NA
Seat Back Failure (deg)	Yes – 35 deg final	NA

TEST DUMMY INFORMATION: TARGET VEHICLE

Description	Driver	Passenger
Dummy Type	50 th	NA
Head Contact		NA
Chest Contact		NA
Abdomen Contact		NA
Left Knee Contact		NA
Right Knee Contact		NA

VIDEO COVERAGE

High Speed	7
Real Time	2
Total	9

Driver ATD Sensors	NA
Passenger ATD Sensors	NA
Bullet Vehicle Structure Accelerometers	9
Target Vehicle Structure Accelerometers	12
Total	21

DATA SHEET NO. 11

GENERAL TEST AND TARGET VEHICLE PARAMETER DATA

Target Vehicle: 1995 Jeep Grand Cherokee
 Test Program: 50 MPH 70% 301 Rear Impact Test Date: 7/1/10

TARGET VEHICLE INFORMATION

Manufacturer	Chrysler / Jeep
Model	Grand Cherokee
Body Style	SUV
Vehicle No.	2
VIN	1J4GZ78Y7SC687528
Color	Painted Red
Delivery Date	June 21, 2010
Odometer Reading	221,078
Dealer	Capitol Auto Auctions
Transmission	Automatic
Final Drive	4WD
Number of Cylinders	8
Engine Displacement (L)	5.2
Engine Placement	Longitudinal

TEST VEHICLE OPTIONS

Driver Airbag	Y
Passenger Airbag	N
Anti-theft System	Y
Cruise Control	Y
Power Windows	Y
Power Steering	Y
Power Door Locks	Y
Tilt Wheel	Y
Air Conditioning	Y
Power Brakes	Y
Disc Brakes, Front	Y
Disc Brakes, Rear	Y
Anti-lock Brakes	Y
AM / FM / Cassette	Y

DATA FROM CERTIFICATION LABEL

Manufactured By	Chrysler Corp.
Date of Manufacture	3/95

GVWR (kg)	2495
GAWR Front (kg)	1248
GAWR Rear (lkg)	1339

DATA FROM TIRE PLACARD

Measured Parameter	Front	Rear
Maximum Tire Pressure (psi)		
Cold Pressure (psi)	33	33
Recommended Tire Size	P225/75R15	P225/75R15
Tire Size On Vehicle	LF ONLY: P245/70R15	P235/75R15
Tire Manufacturer	Goodyear Wrangler GSA	Sigma I Stampede Radial

Measured Parameter	Front	Rear	Third	Total
Type of Seats	Bucket	Bench	NA	NA
Number of Occupants	2	3	NA	3
Capacity Wt. (VCW) (kg)				780.5
Cargo Wt. (RCLW) (kg)				440.5

DATA SHEET NO. 12

GENERAL TEST AND TARGET VEHICLE PARAMETER DATA

Target Vehicle: 1995 Jeep Grand Cherokee
Test Program: 50 MPH 70% 301 Rear Impact Test Date: 7/1/10

TARGET VEHICLE WEIGHTS

	Units	As Delivered (UVW) (Axle)			As Tested (ATW) (Axle)		
		Front	Rear	Total	Front	Rear	Total
Left	kg	519	343.5	862.5	535	416.5	951.5
Right	kg	523	329	852	539.5	365.5	905
Ratio	%	60.8	39.2		57.9%	42.1%	
Totals	kg	1042	672.5	1714.5	1074.5	782	1856.5

TARGET VEHICLE TARGET TEST WEIGHT CALCULATION

Measured Parameter	Units	Value
Total Delivered Weight	kg	1714.5
Weight of 1 P572E ATD	kg	78
Rated Cargo / Luggage Weight (RCLW)	kg	136
Calculated Vehicle Target Weight (TVTW)	kg	1929

TARGET VEHICLE ATTITUDES

	Units	LF	RF	LR	RR
As Delivered	mm	848	848	883	876
As Tested	mm	841	844	865	863
Post Test	mm	845	829	857	749

Weight of Ballast: _____

Vehicle Components Removed: oil, trans fluid, antifreeze, fuel

Weight Removed: 21.5 kg

Added: battery box, data acquisition, brake system, Stoddard

Weight Added: 114.5 kg

DATA SHEET NO. 13

TARGET VEHICLE TIRE INFORMATION

Target Vehicle: 1995 Jeep Grand Cherokee
 Test Program: 50 MPH 70% 301 Rear Impact Test Date: 7/1/10

Vehicle Year	1995	Vehicle Make	Jeep
VIN	1J4GZ78Y7SC687528	Vehicle Model	Grand Cherokee

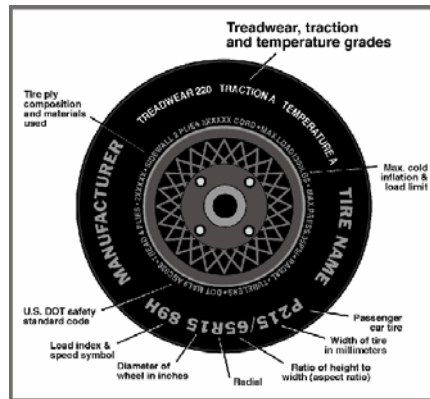

	Left Front	Right Front
Tire Manufacturer	Goodyear	Sigma I
Tire Name	Wrangler GS-A	Stampede Radial A/T
Tire Type	P	P
Tire Width (mm)	245	235
Ratio of Height to Width (aspect ratio)	70	75
Radial	R	R
Wheel Diameter	15	15
Load Index & Speed Symbol		
Treadwear	340	500
Traction Grade	A	A
Temperature Grade	B	B
	Left Rear	Right Rear
Tire Manufacturer	Sigma I	Sigma I
Tire Name	Stampede Radial A/T	Stampede Radial A/T
Tire Type	P	P
Tire Width (mm)	235	235
Ratio of Height to Width (aspect ratio)	75	75
Radial	R	R
Wheel Diameter	15	15
Load Index & Speed Symbol		
Treadwear	500	500
Traction Grade	A	A
Temperature Grade	B	B

DATA SHEET NO. 14

TARGET VEHICLE SEAT INFORMATION

Target Vehicle: 1995 Jeep Grand Cherokee
Test Program: 50 MPH 70% 301 Rear Impact Test Date: 7/1/10

NORMAL DESIGN RIDING POSITION

Driver Seat Back Angle: 24 deg
Passenger Seat Back Angle: NA deg

(20° rearward of most forward locked position.)

SEAT FORE / AFT POSITION

The driver and passenger seats are operated:
(manually / **electrically**)

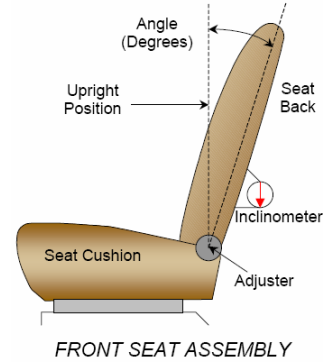

Driver Seat Fore / Aft Total Travel: 195 positions / **mm**
Passenger Seat Fore / Aft Total Travel: 190 positions / **mm**

As Tested:

Driver Seat Fore / Aft Position: 97.5 mm, center of travel
Passenger Seat Fore / Aft Position: full rearward to accommodate instrumentation

SEAT BELT UPPER ANCHORAGE

The seat belt anchorages were placed in _____ position of _____ with the top position as one.

or **No Adjustment Available**

SEAT HEIGHT ADJUSTMENT

Seat is positioned at its lowest setting

NOTES: Any driver's seat motion other than seat back failure was unable to be examined due to crush locked driver's side front door

DATA SHEET NO. 14... (continued)

TARGET VEHICLE INFORMATION

Target Vehicle: 1995 Jeep Grand Cherokee

Test Program: 50 MPH 70% 301 Rear Impact

Test Date: 7/1/10

STEERING COLUMN ADJUSTMENT

The steering column was placed in the mid position of travel.

Pos.	Desc	Angle
3	Full Up	50
2	Center	65
1	Full Down	80

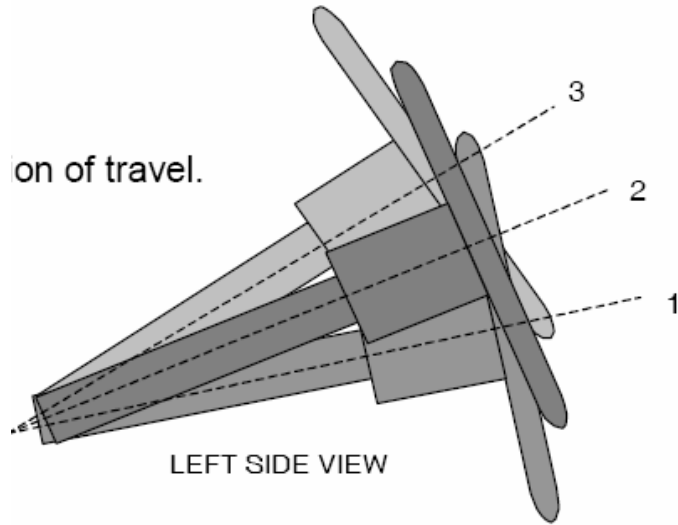

STEERING COLUMN ASSEMBLY

DATA SHEET NO. 15

TARGET VEHICLE DUMMY POSITIONING IN VEHICLE

Target Vehicle: 1995 Jeep Grand Cherokee

Test Program: 50 MPH 70% 301 Rear Impact

Test Date: 7/1/10

DUMMY MEASUREMENTS FOR FRONT SEAT OCCUPANTS

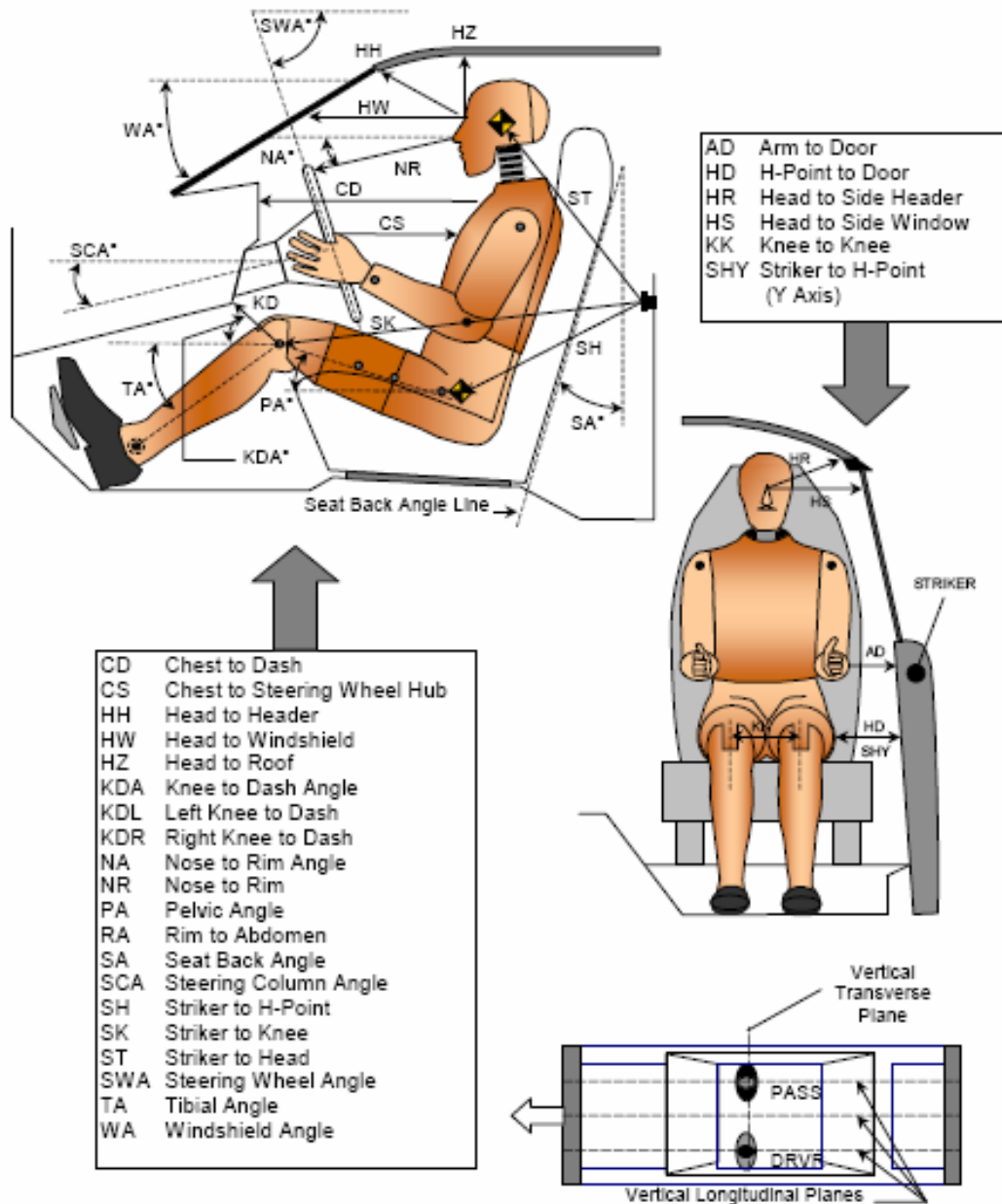

DATA SHEET NO. 15...(continued)

TARGET VEHICLE DUMMY POSITIONING IN VEHICLE

Target Vehicle: 1995 Jeep Grand Cherokee

Test Program: 50 MPH 70% 301 Rear Impact

Test Date: 7/1/10

Code	Measurement Description	Driver		Passenger	
		Length (mm)	Angle (°)	Length (mm)	Angle (°)
WA	Windshield Angle		35		
SWA	Steering Wheel Angle		25		
SCA	Steering Column Angle		25		
SA	Seat Back Angle (head rest post)		24		
HZ	Head to Roof (Z)	235			
HH	Head to Header	560			
HW	Head to Windshield	800			
HR	Head to Side Header (Y)	250			
NR	Nose to Rim	620			
CD	Chest to Dash	700			
CS	Chest to Steering Hub	350			
RA	Rim to Abdomen				
KDL	Left Knee to Dash	85			
KDR	Right Knee to Dash	80			
PA	Pelvic Angle		16		
TA	Tibia Angle				
KK	Knee to Knee (Y)	290			
SK	Striker to Knee	64			
ST	Striker to Head	590			
SH	Striker to H-Point	210			
SHY	Striker to H-Point (Y)	200			
HS	Head to Side Window	310			
HD	H-Point to Door	165			
AD	Arm to Door (Y)	80			
AA	Ankle to Ankle				

DATA SHEET NO. 16

TARGET VEHICLE SEAT BELT POSITIONING DATA

Target Vehicle: 1995 Jeep Grand Cherokee

Test Program: 50 MPH 70% 301 Rear Impact

Test Date: 7/1/10

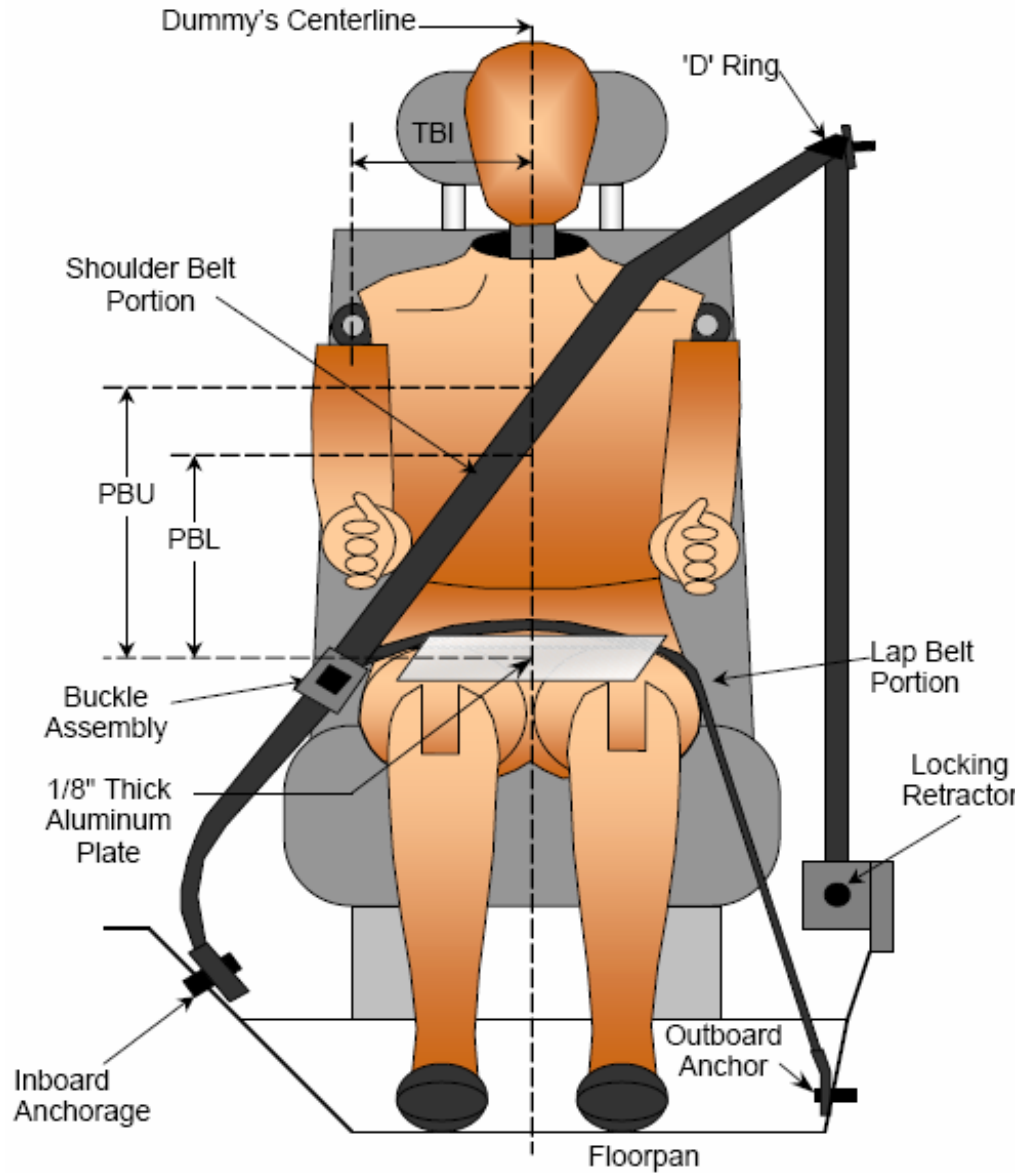

SEAT BELT POSITIONING MEASUREMENTS

Measurement Description	Units	Driver	Passenger
PBU – Top surface of reference to belt upper edge	mm	370	
PBL – Top surface of reference to belt lower edge	mm	290	

DATA SHEET NO. 17

TARGET VEHICLE MEASUREMENTS

Target Vehicle: 1995 Jeep Grand Cherokee

Test Program: 50 MPH 70% 301 Rear Impact

Test Date: 7/1/10

No.	Measurement	Units	Pre-Test	Post-Test	Difference
1	Total length of vehicle at centerline	Mm	4464	4127.5	336.5
4	FSOV to leading edge of right door	Mm	1359	133.5	25.5
5	FSOV to leading edge of left door	Mm	1374.7	1374.7	0
6	FSOV to lower leading edge of right door	Mm	1448	1397	51
7	FSOV to lower leading edge of left door	Mm	1461	1460.5	0.5
8	FSOV to upper leading edge of right door	Mm	1975	1397	578
9	FSOV to upper leading edge of left door	Mm	1975.1	1975.1	0
	FSOV to trailing edge of right door	Mm	2445	2413	32
	FSOV to trailing edge of left door	Mm	2445	2438.4	6.6
10	FSOV to lower trailing edge of right door	Mm	2470	2463.8	6.2
11	FSOV to lower trailing edge of left door	Mm	2477	2476.5	0.5
	FSOV to upper trailing edge of right door	Mm	2515	2501.9	13.1
	FSOV to upper trailing edge of left door	Mm	2534	2489.2	44.8
	FSOV to trailing edge of rr door	Mm	3353	3314.7	38.3
	FSOV to trailing edge of lr door	Mm	3359	3352.8	6.2
	FSOV to lower edge of rr door	Mm	3061	3009.9	51.1
	FSOV to lower edge of lr door	Mm	3061	3060.7	0.3
	FSOV to upper trailing edge of rr door	Mm	3226	3213.1	12.9
	FSOV to upper trailing edge of lr door	Mm	3226	3213.1	12.9
12	FSOV to bottom of right 'A' pillar	Mm	1448	1295.4	152.6
13	FSOV to bottom of left 'A' pillar	Mm	1448	1422.4	25.6
	FSOV to bottom of right 'B' pillar	Mm	2438	2413	25
	FSOV to bottom of left 'B' pillar	Mm	2441.5	2441.5	0
	FSOV to bottom of right 'C' pillar	Mm	3327	3314.7	12.3
	FSOV to bottom of left 'C' pillar	Mm	3333.9	3333.9	0
16	FSOV to steering column	Mm	1905	1905	0
17	Center of steering column to left 'A' pillar	Mm	457	292.1	164.9
18	Center of steering column to headlining	Mm	483	457.2	25.8
19	FSOV to right side of rear bumper	Mm	4407	4165.6	241.4
20	FSOV to left side of rear bumper	Mm	4420	3670.3	749.7
C1	Crush Zone 1 at right side	Mm	4432		
C2	Crush Zone 2 at right side	Mm	4445		
C3	Crush Zone 3 at right side	Mm	4458		
C4	Crush Zone 4 at left side	Mm	4458		
C5	Crush Zone 5 at left side	Mm	4445		
C6	Crush Zone 6 at left side	Mm	4432		

DATA SHEET NO. 17... (continued)

TARGET VEHICLE MEASUREMENTS

Target Vehicle:

1995 Jeep Grand Cherokee

Test Program:

50 MPH 70% 301 Rear Impact

Test Date:

7/1/10

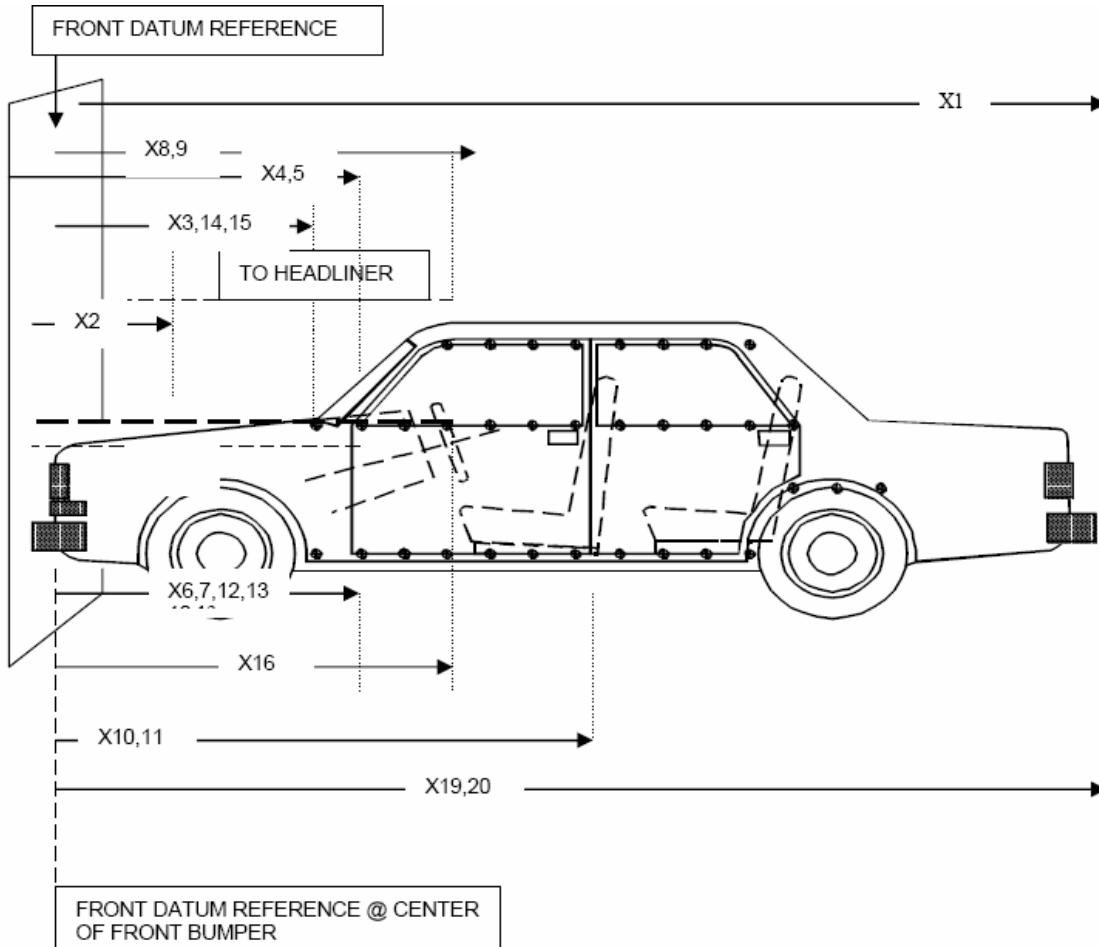

DATA SHEET NO. 17... (Continued)

TARGET VEHICLE MEASUREMENTS

Target Vehicle: 1995 Jeep Grand Cherokee

Test Program: 50 MPH 70% 301 Rear Impact

Test Date: 7/1/10

	Elements	Pre-Test (mm)
1	Total Length	4458
2	Total Width	1803
3	Rear Bumper Top Height	692
4	Rear Bumper Bottom Height	533
5	Longitudinal Member Top Height	
6	Distance Between Longitudinal Members	
7	Longitudinal Member Width	
8	Engine Top Height	NA
9	Engine Bottom Height	NA
10	Engine and Gearbox Width	NA
11	Front Bumper – Engine Distance	NA
12	Front Shock Absorber Fixing Height	NA
13	Bonnet Leading Edge Height	NA
14	Front Shock Absorber Fixing Width	NA
15	Rear Bumper – Rear Axle distance	953
16	Front Axle – A Pillar Distance	599
17	A-Pillar – B-Pillar Distance	1016
	C-Pillar – Rear Axle Distance	165
	B-Pillar – C-Pillar Distance	902
20	Roof Sill Bottom Height	1626
21	Roof Sill Top Height	1676
22	Floor Sill Bottom Height	381
23	Floor Sill Top Height	546

DATA SHEET NO. 18

TARGET VEHICLE ACCELEROMETER LOCATIONS & MEASUREMENTS

Target Vehicle: 1995 Jeep Grand Cherokee

Test Program: 50 MPH 70% 301 Rear Impact

Test Date: 7/1/10

Location	X (mm)	Y (mm)	Z (mm)
CG	1905	-6	584.2

X Reference from the front bumper – positive towards the rear of the vehicle

Y Reference from the center line – positive towards the right side of the vehicle

Z Reference from the ground – positive up

Description of Instrumentation Included:

Tri-axial accelerometers and tri-axial roll rate at cg w/ full redundant

DATA SHEET NO. 19

TARGET VEHICLE TARGET MEASUREMENTS

Target Vehicle: 1995 Jeep Grand Cherokee

Test Program: 50 MPH 70% 301 Rear Impact

Test Date: 7/1/10



Side Marker Measurements

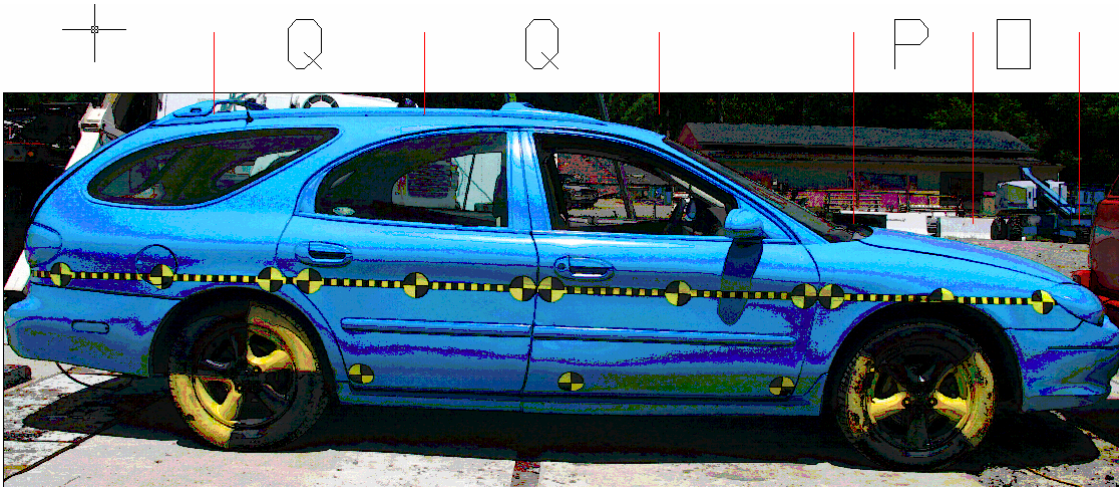

Top Marker Measurements

DATA SHEET NO. 19...Continued

TARGET VEHICLE PHOTOGRAPHIC REFERENCE TARGET LOCATIONS

Target Vehicle: 1995 Jeep Grand Cherokee

Test Program: 50 MPH 70% 301 Rear Impact

Test Date: 7/1/10

	Driver's Side Middle		Passenger's Side Middle	
	Pre	Post	Pre	Post
A	465	465	-	464
B	462	462	460	460
C	110	106	110	108
D	485	483	480	481
E	485	484	484	483
F	109	97	115	109
G	404	397	404	403
H	400	397	399	400
I	108	78	110	95
J	353	349	350	349
K	353	178	360	352
	Driver's Side Low		Passenger's Side Low	
L	860	860	863	864
M	860	860	858	857
	Top			
	Pre		Post	
O	428		429	
P	418		406	
Q	1032		1035	
R	1028		1028	

DATA SHEET NO. 20

TARGET VEHICLE INTRUSION MEASUREMENTS

Target Vehicle: 1995 Jeep Grand Cherokee

Test Program: 50 MPH 70% 301 Rear Impact

Test Date: 7/1/10

DOOR OPENING WIDTH

Item	Description	Units	Pre-Test	Post-Test	Difference
A	Left Side Upper	mm	1003		
B	Left Side Lower	mm	978		
D	Right Side Upper	mm	1003	999	
E	Right Side Lower	mm	978	940	
	Rear Left Side Upper	mm	826		
	Rear Left Side Lower	mm	572		
	Rear Right Side Upper	mm	826		
	Rear Right Side Lower	mm	572		

WHEELBASE MEASUREMENTS

Item	Description	Units	Pre-Test	Post-Test	Difference
C	Left Side Wheelbase	mm	2667	2518	
F	Right Side Wheelbase	mm	2667	2670	

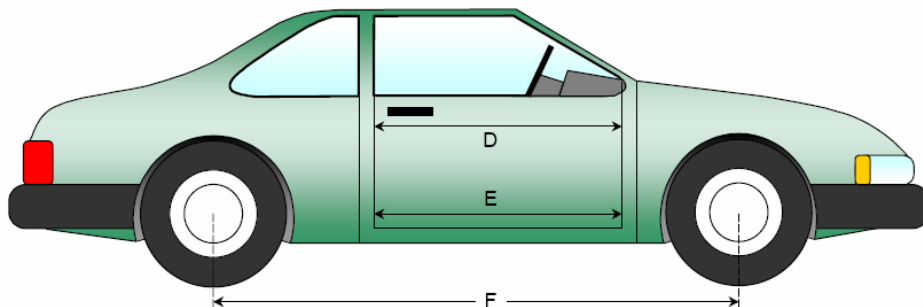
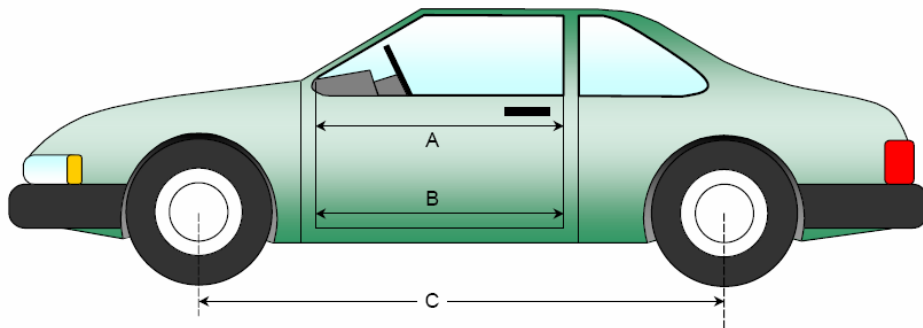

DATA SHEET NO. 21

TARGET VEHICLE ACCIDENT INVESTIGATION DIVISION DATA

Target Vehicle: 1995 Jeep Grand Cherokee
Test Program: 50 MPH 70% 301 Rear Impact Test Date: 7/1/10

VEHICLE INFORMATION

VIN: 1J4GZ78Y7SC687528 Wheelbase (mm): 2667 mm
Vehicle Size Category: 3 Test Weight (kg): 1856.5 kg

ACCELEROMETER DATA

Accelerometer Locations: AT CG
Cal. Procedure / Interval: _____
Integration Algorithm: _____ Linearity: _____
Impact Velocity (kph): 0 kph
Velocity Change (kph): 37.0 mph Time of Separation (ms): 224

CRUSH PROFILE

Collision Deformation Classification: 06BWD A7 Midpoint of damage: -247 mm
Damage Region Length (mm): 1308 mm Impact Mode: _____

No.	Measurement Description	Units	Pre-Test	Post-Test	Difference
C1	Crush Zone 1 at left side	mm	114, 25	343, 940	
C2	Crush Zone 2 at left side	mm	424, 13	604, 864	
C3	Crush Zone 3 at left side	mm	734, 0	866, 876	
C4	Crush Zone 4 at Right Side	mm	1044, 0	1128, 787	
C5	Crush Zone 5 at Right Side	mm	1354, 13	1389, 546	
C6	Crush Zone 6 at Right Side	mm	1664, 25	1651, 559	
L	C1 to C6	mm	1549	1308	

DATA SHEET NO. 22

CAMERA LOCATIONS

Bullet Vehicle: 2000 Ford Taurus

Target Vehicle: 1995 Jeep Grand Cherokee

Test Program: 50 MPH 70% 301 Rear Impact Test Date: 7/1/10

No.	Camera View	Location (mm)			Lens (mm)	Speed (fps)
		X	Y	Z		
1	Real Time					
2	Overall Target Vehicle Driver's Side					
3	Target Vehicle Driver's Side					
4	Target Vehicle Driver's Closeup					
5	Bullet Vehicle Driver's Side					
6	Overall Target Vehicle Passenger's Side					
7	Target Vehicle Passenger's Side					
8	Overhead Wide (not shown)					
9						
10						
11						

Coordinates

- +X = film plane forward of impact point
- +Y = film plane to right of monorail centerline
- +Z = film plane above ground level

Camera	Coverage Description
2	Entire bullet and target vehicle
3	Entire target vehicle
4	Driver's Area (just behind B pillar to just in front of A pillar)
5	Entire bullet vehicle
6	Entire bullet and target vehicle
7	Entire target vehicle

NOTE: all cameras should cover the specified object from the point of impact through the first 15 ft of motion.

DATA SHEET NO. 27... (continued)

CAMERA LOCATIONS

Bullet Vehicle:

2000 Ford Taurus

Target Vehicle:

1995 Jeep Grand Cherokee

Test Program:

50 MPH 70% 301 Rear Impact

Test Date:

7/1/10

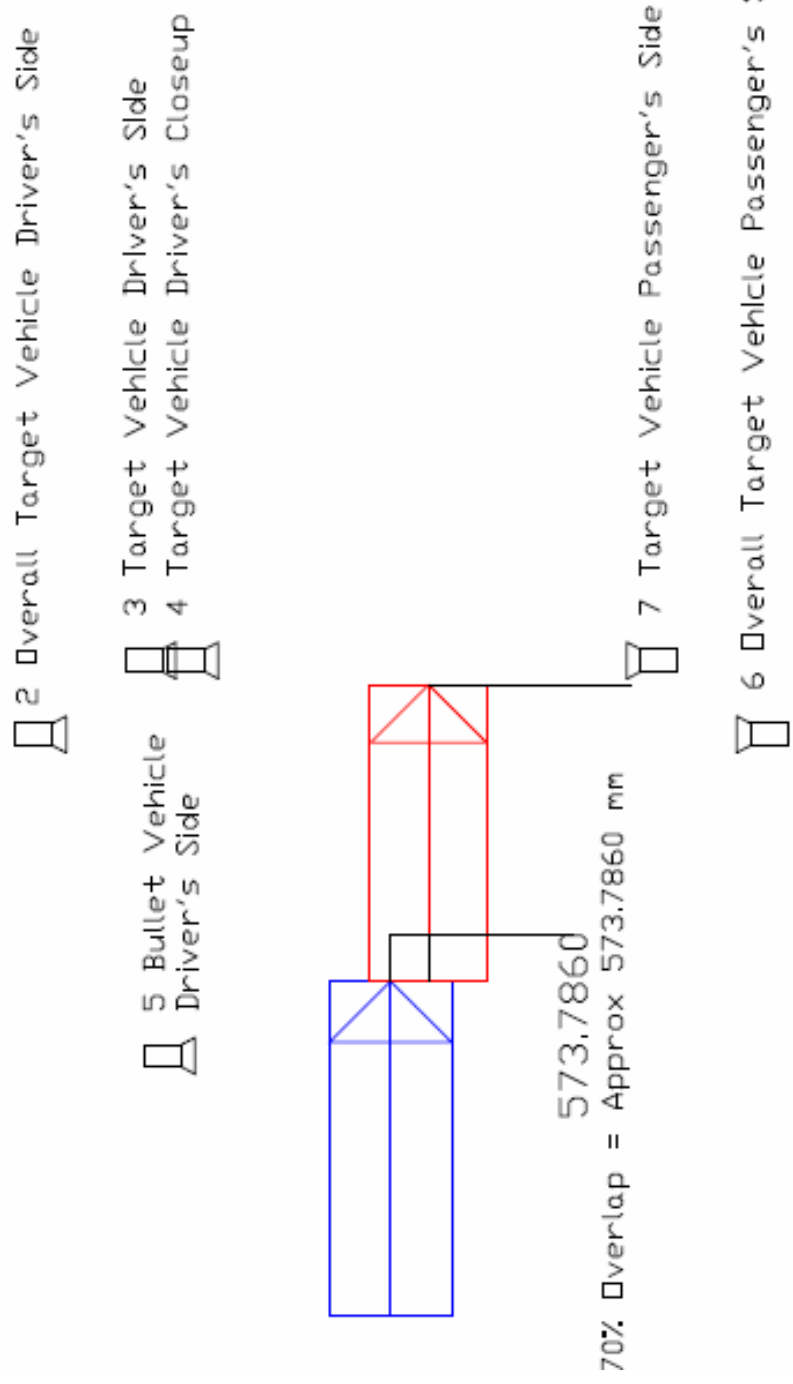

APPENDIX A

PHOTOGRAPHS PRE-TEST

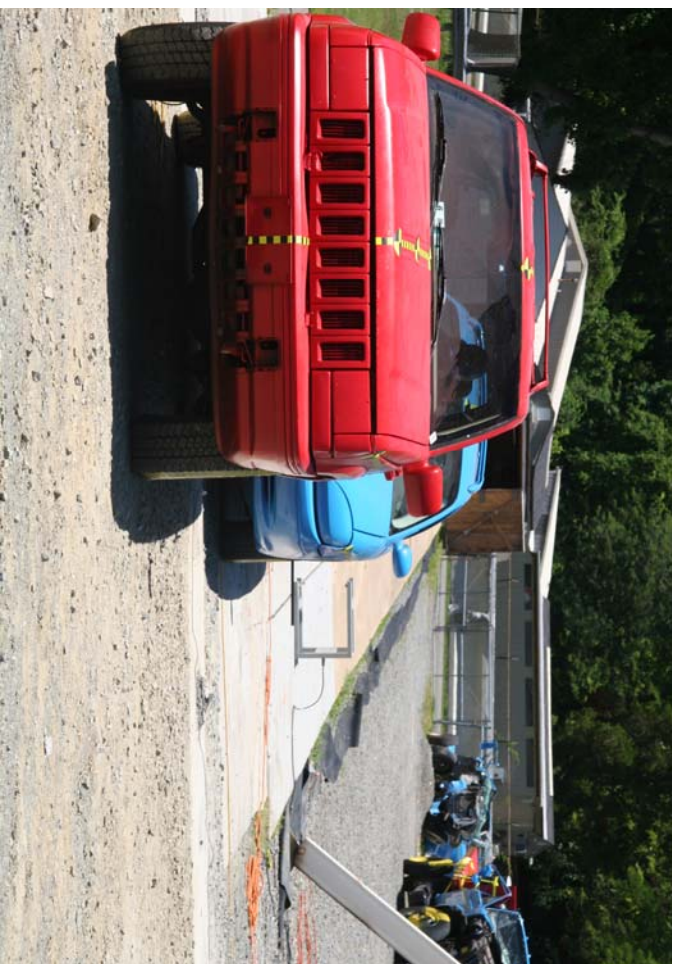

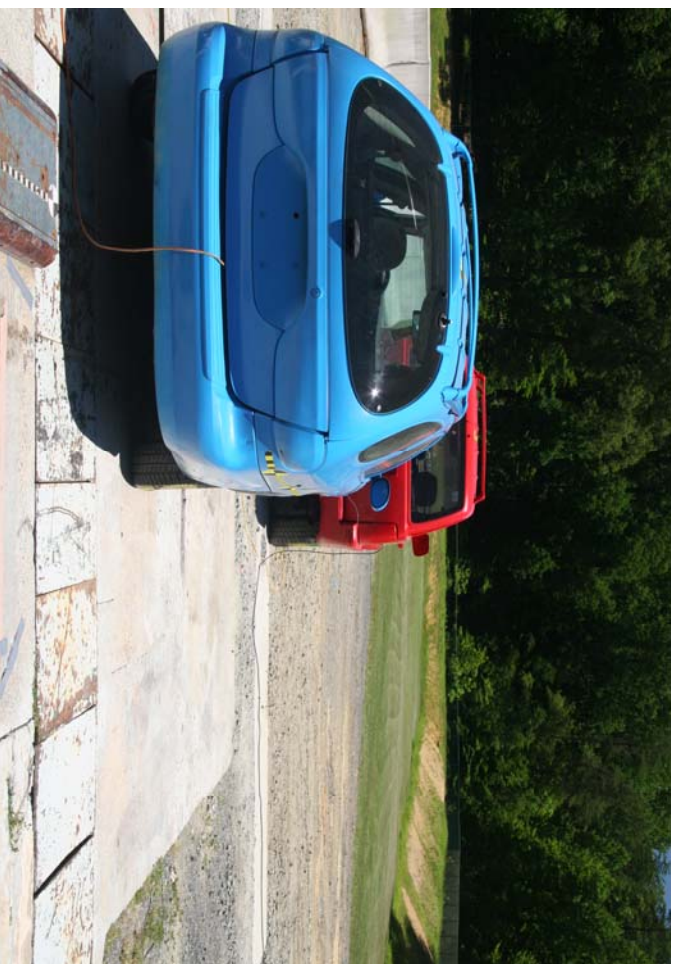
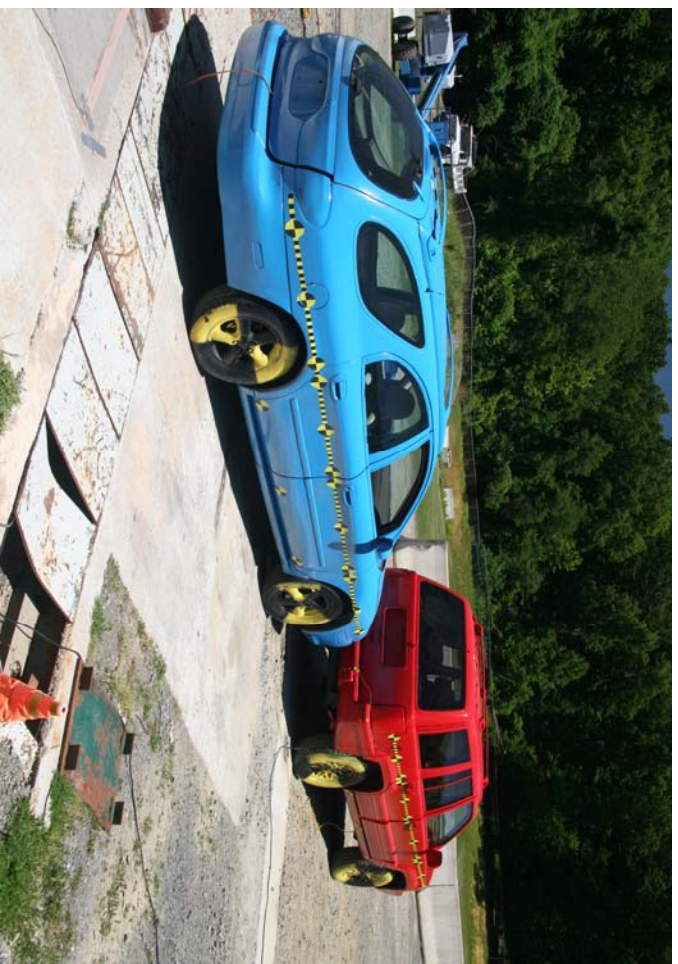
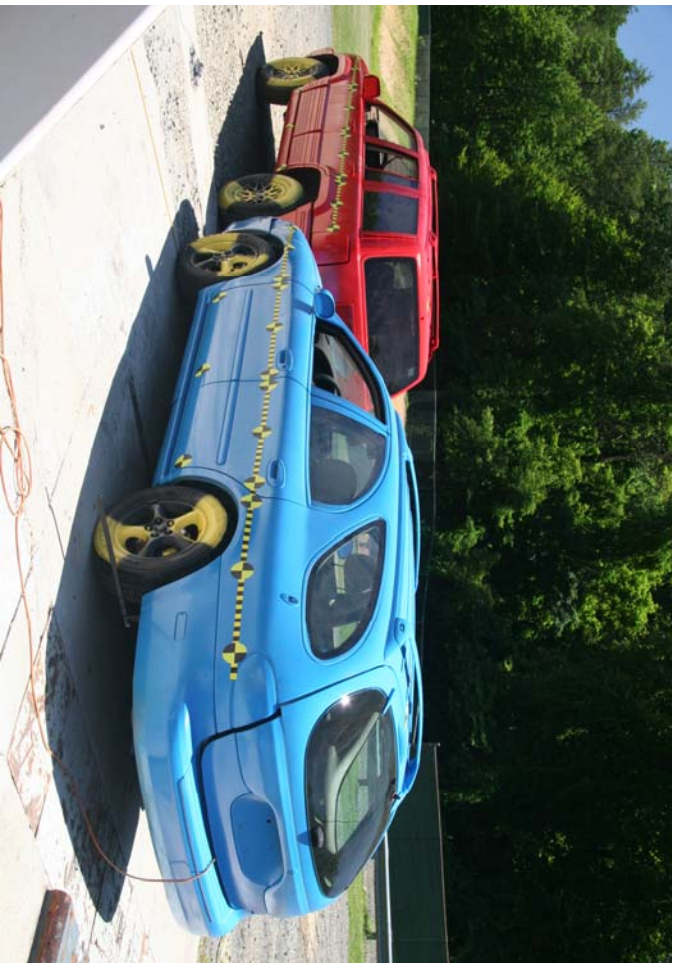



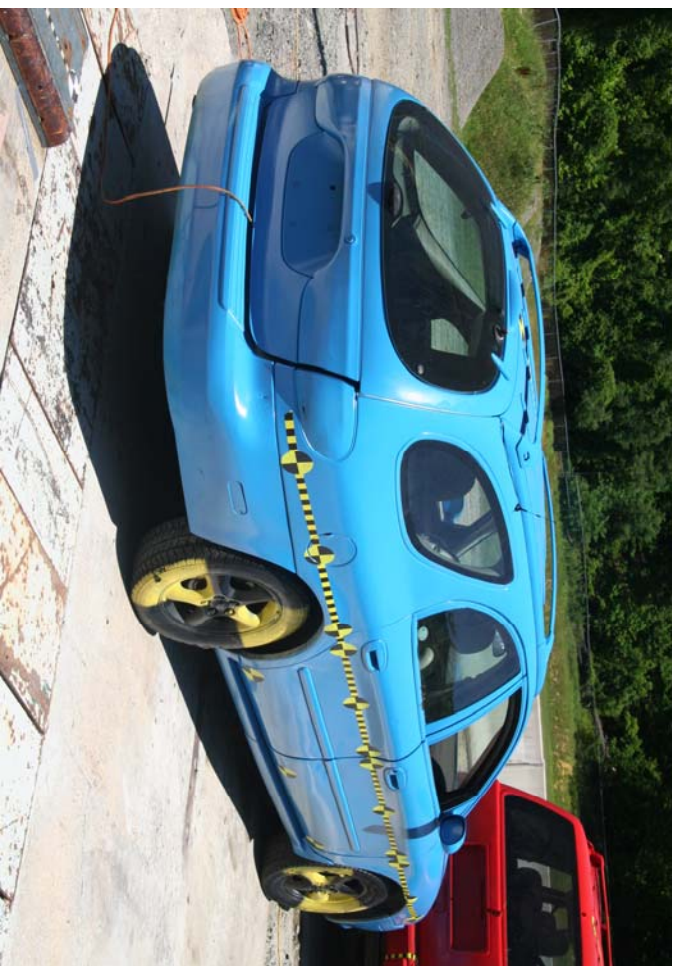
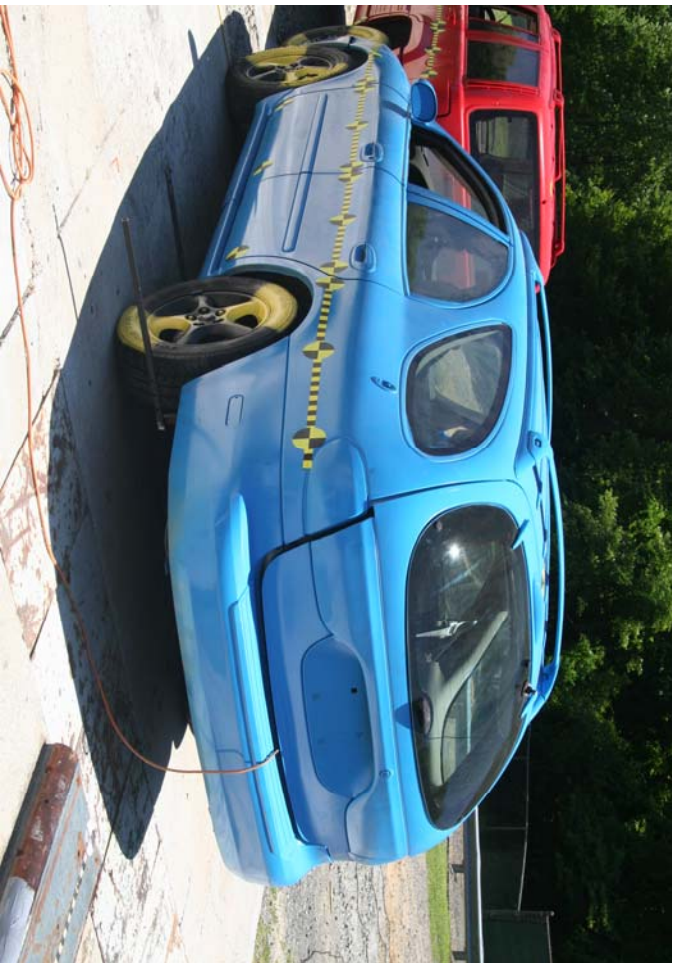

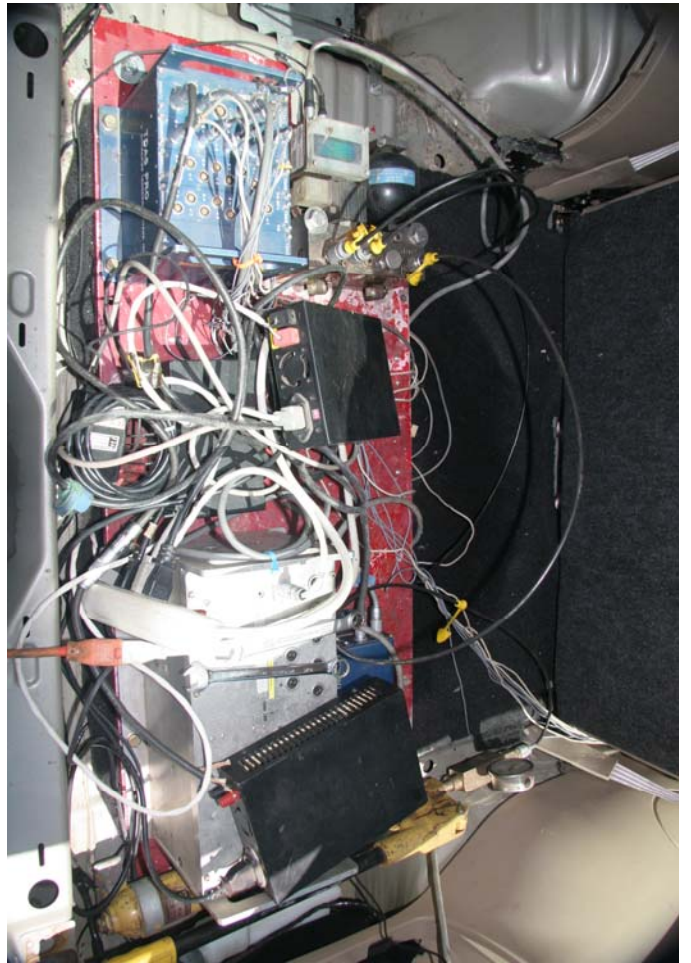
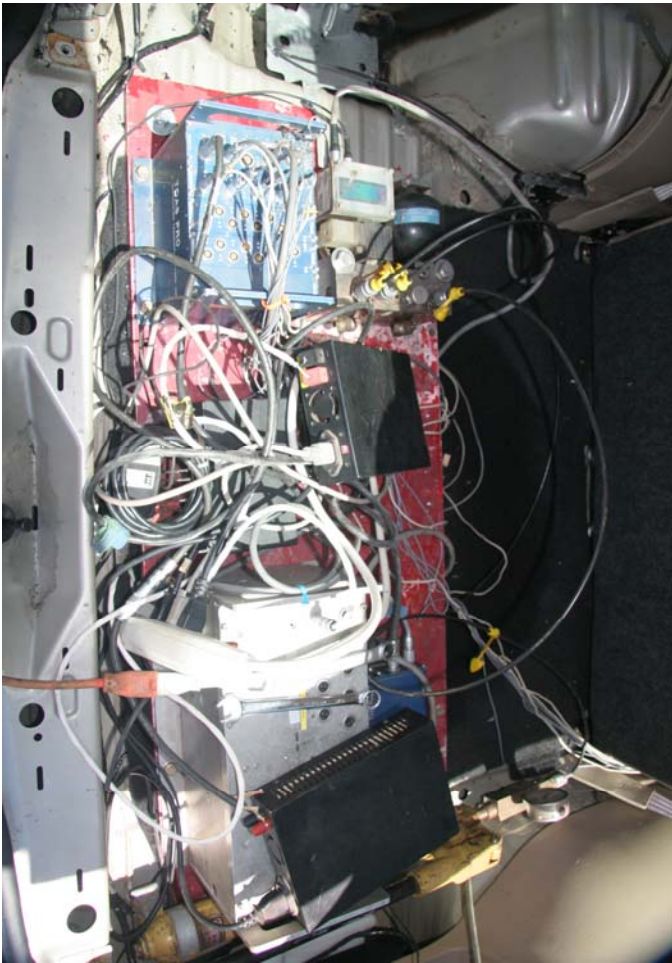



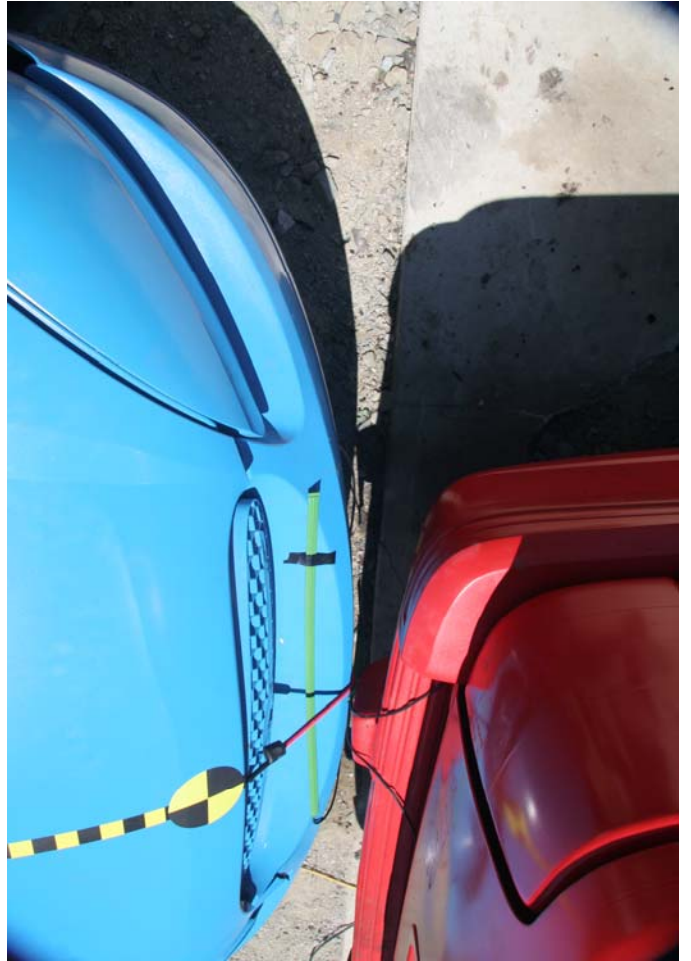
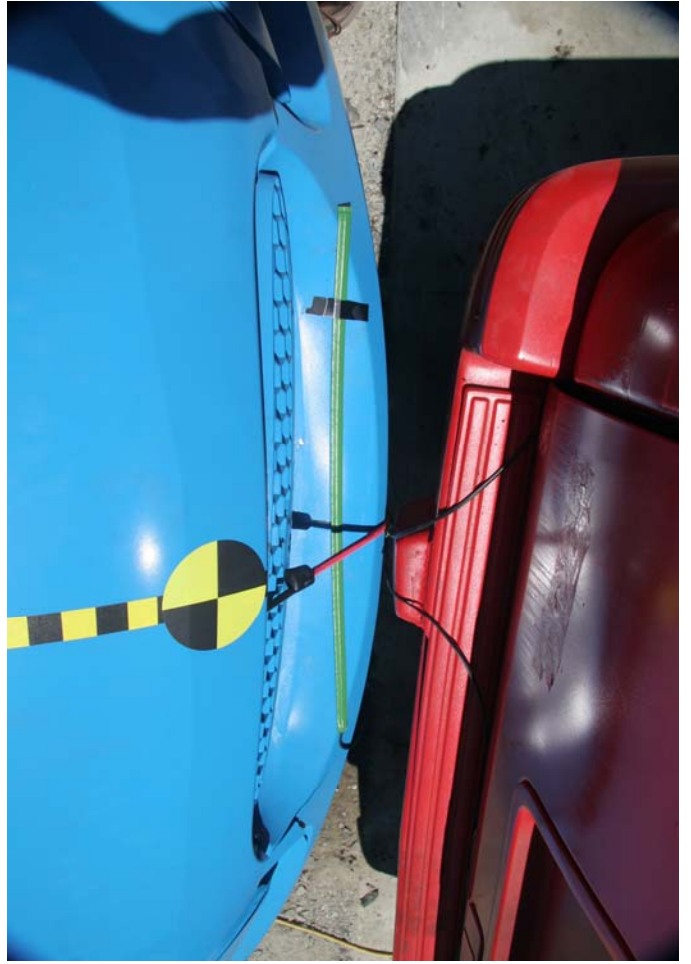





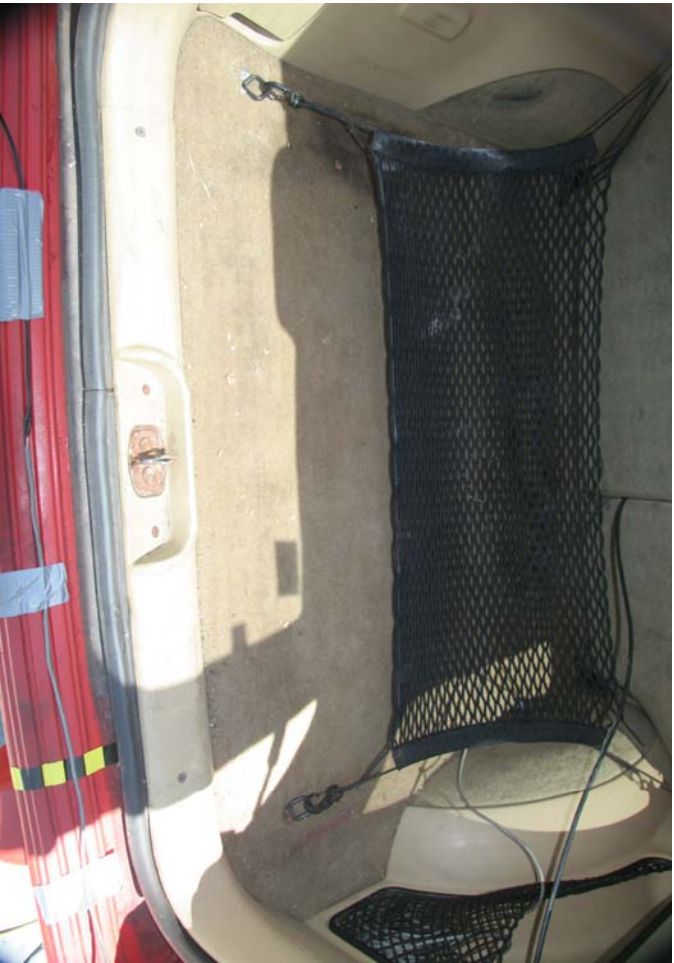

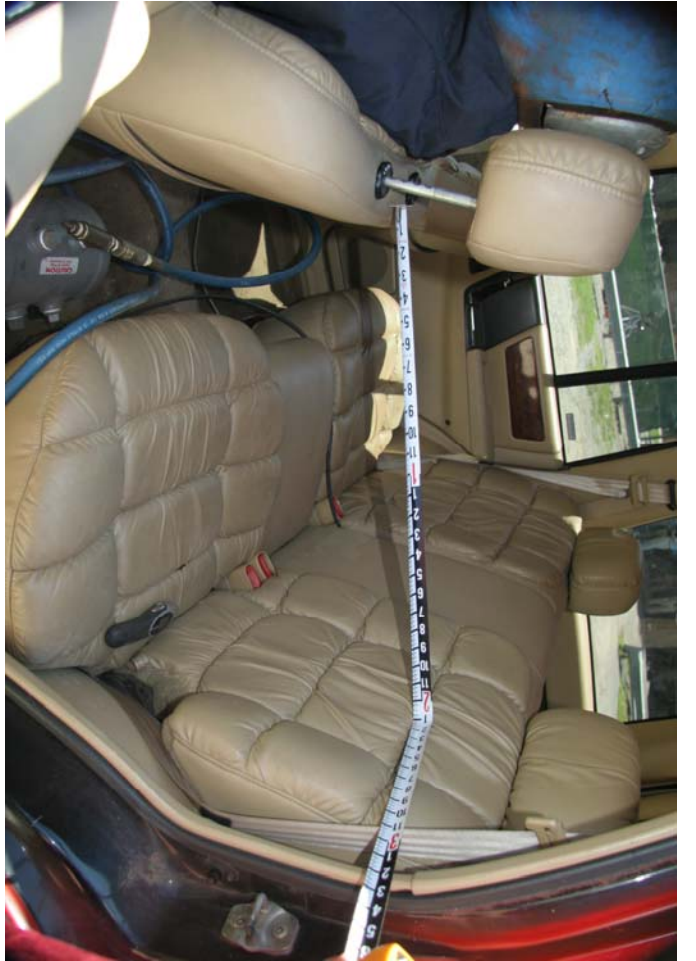

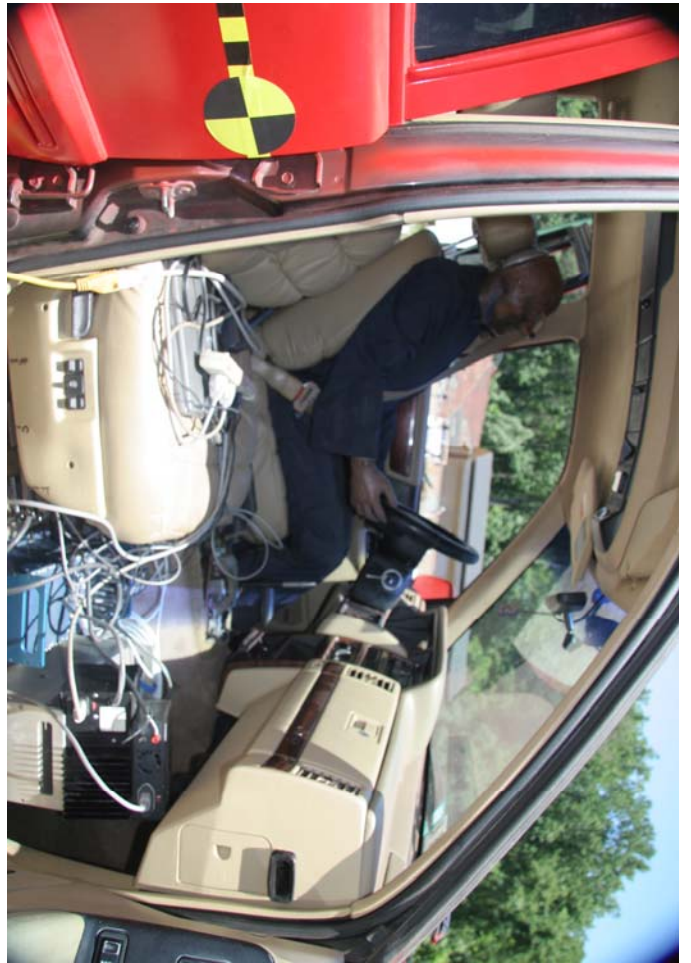





PHOTOGRAPHS PRE-TEST

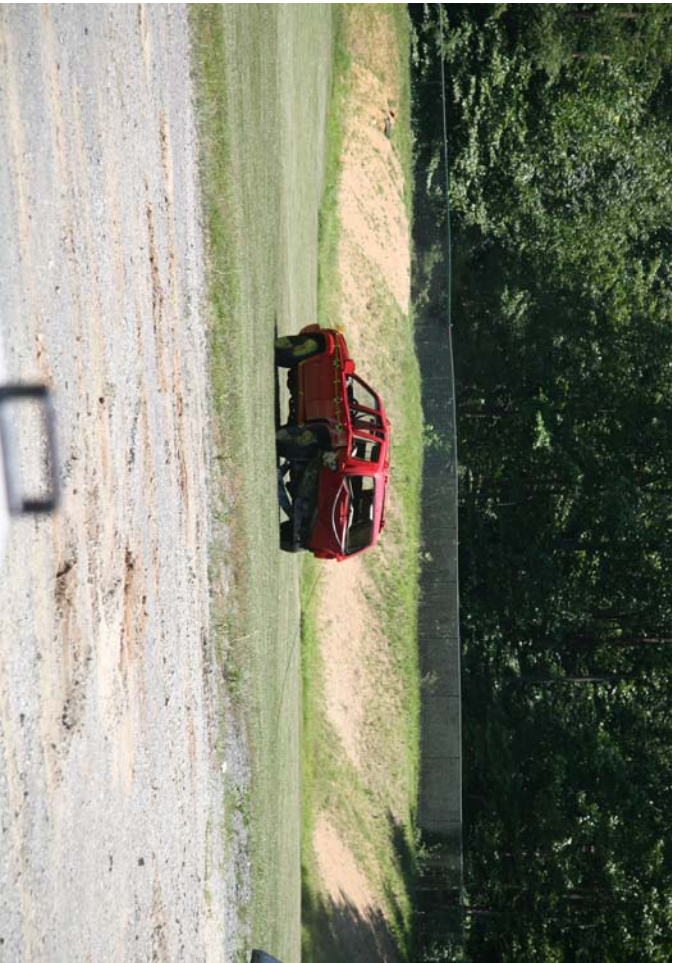

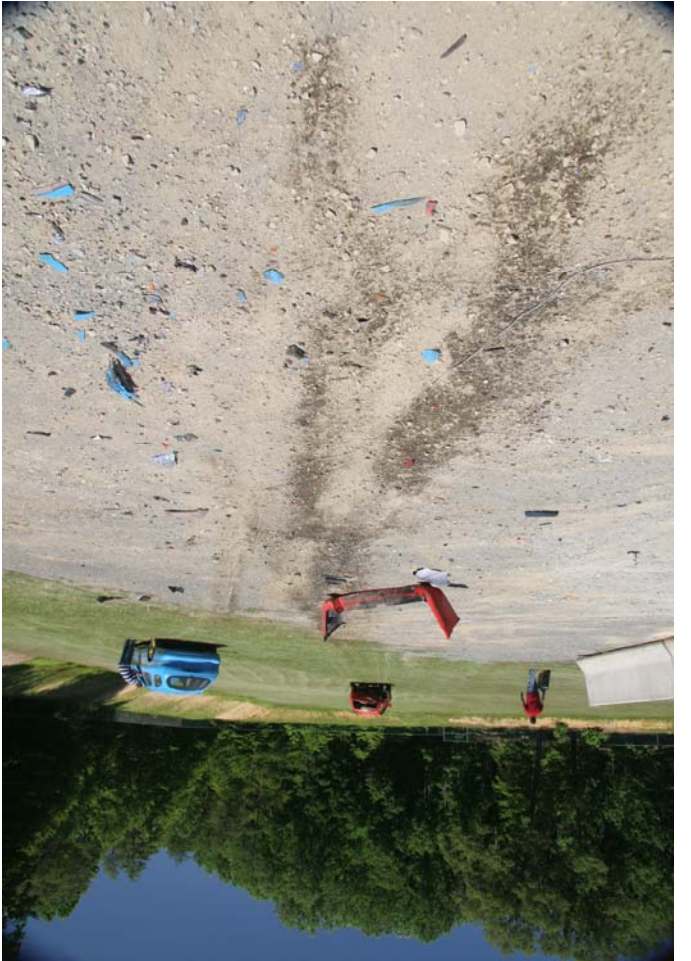
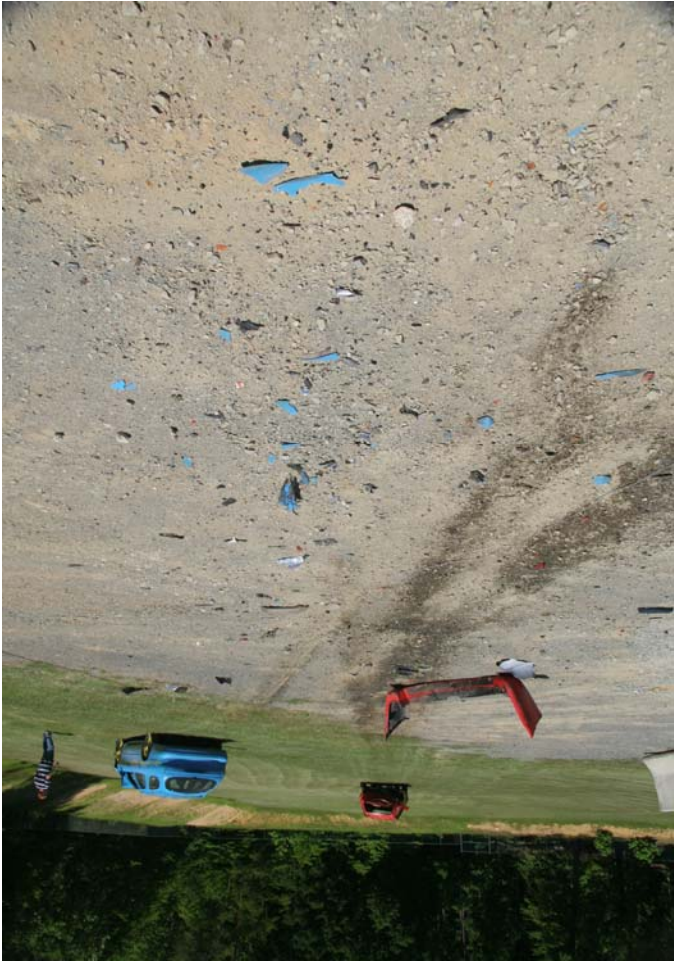



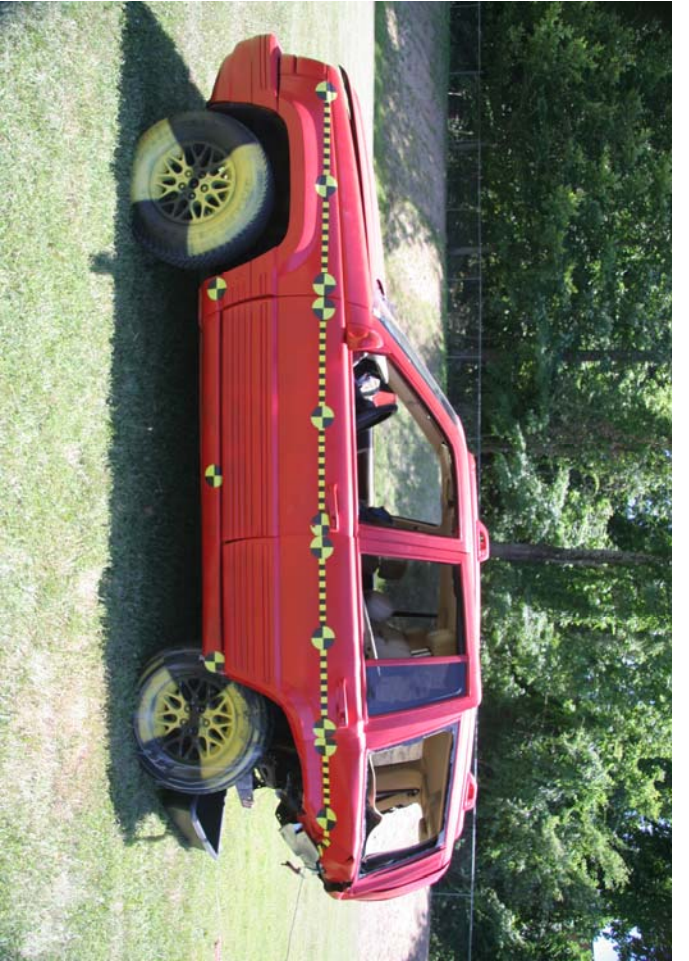



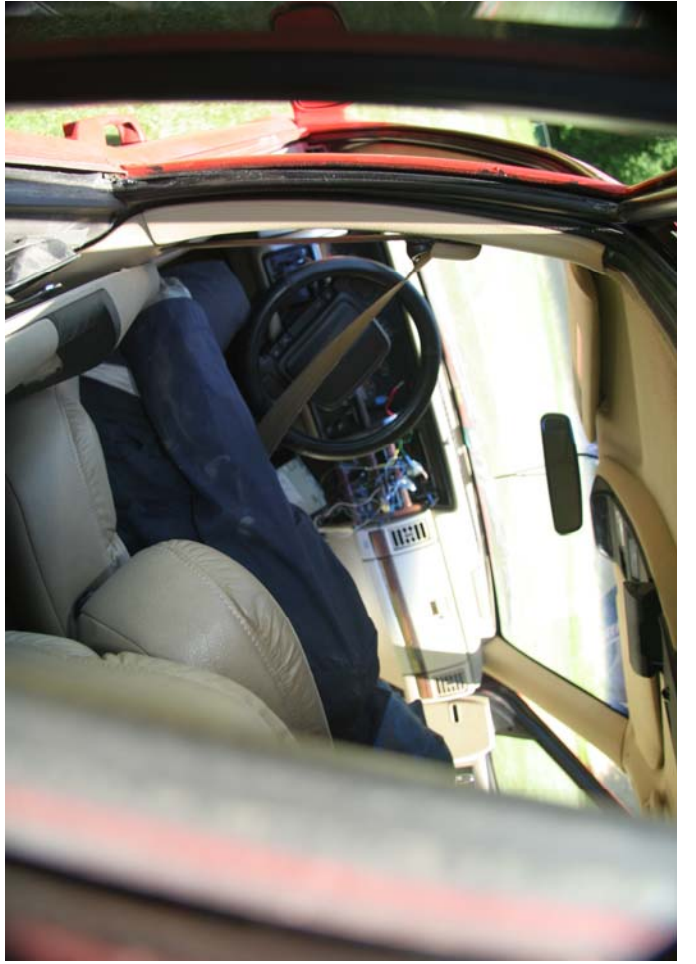

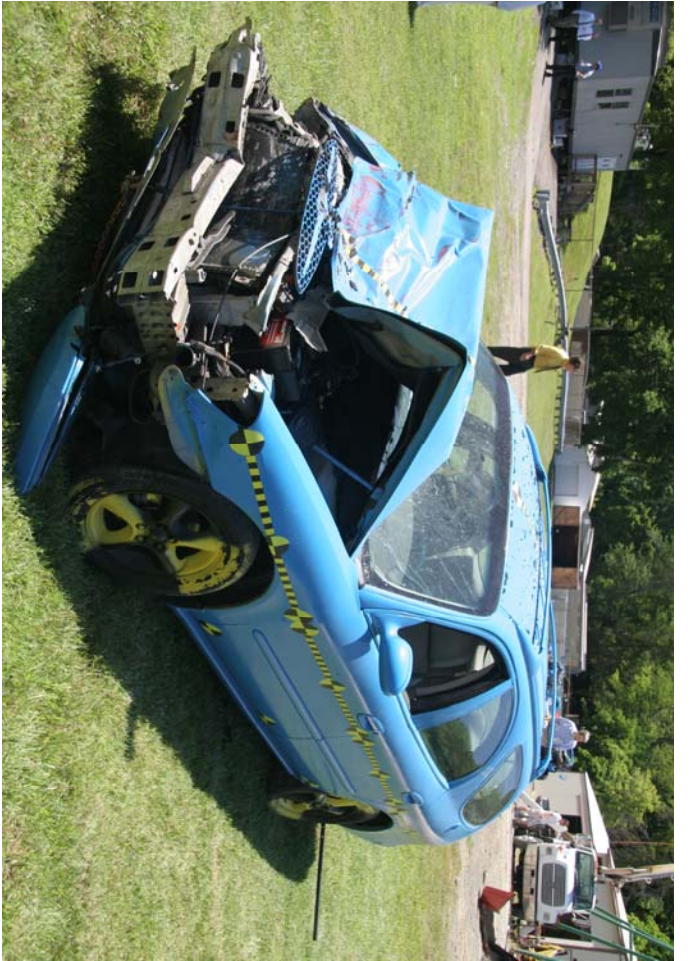
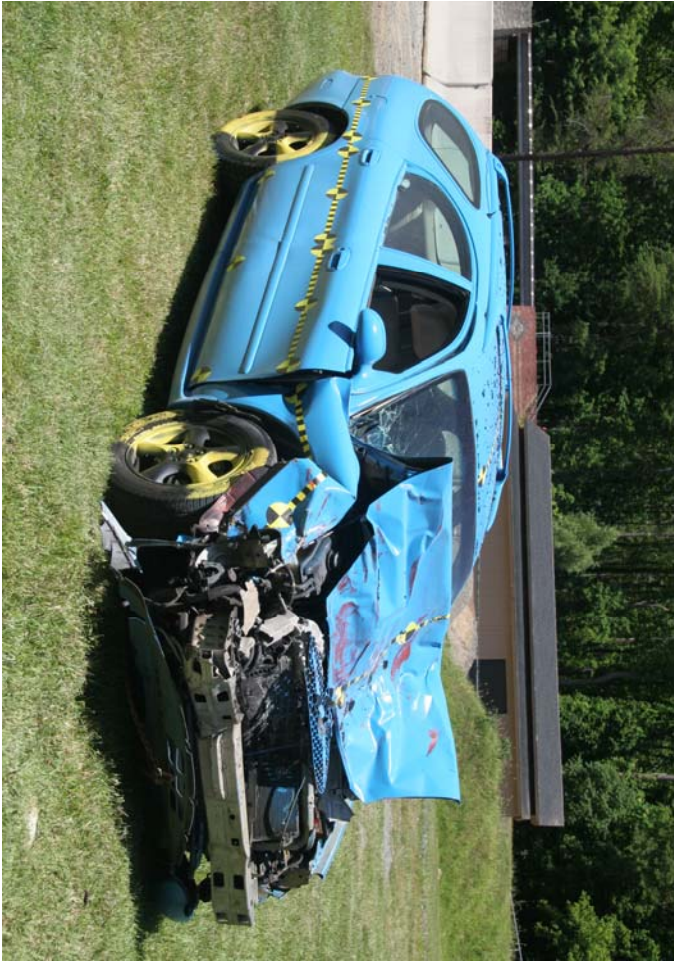





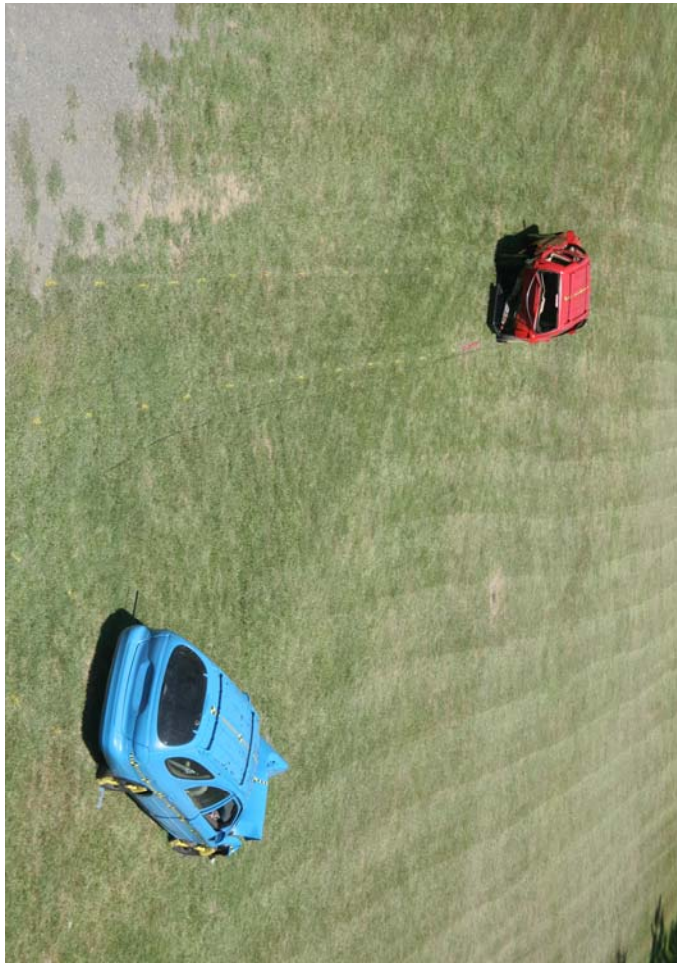

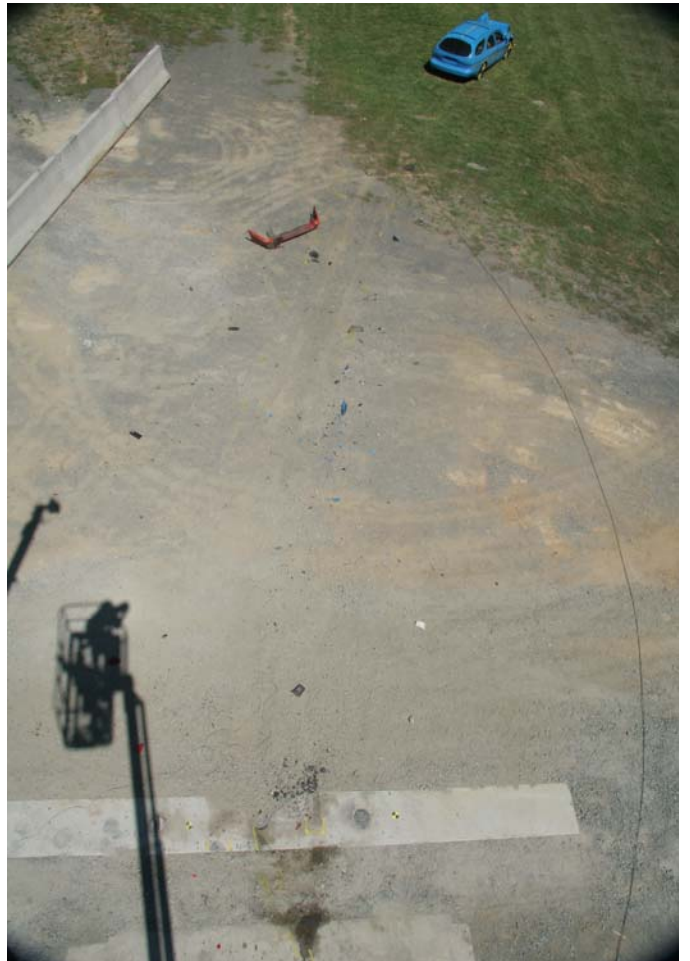
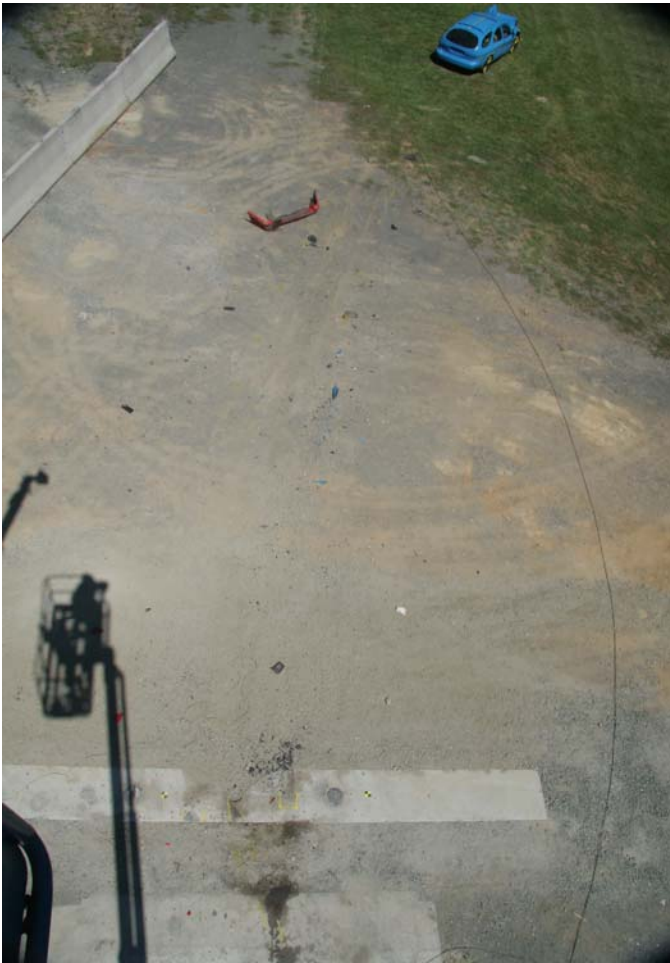

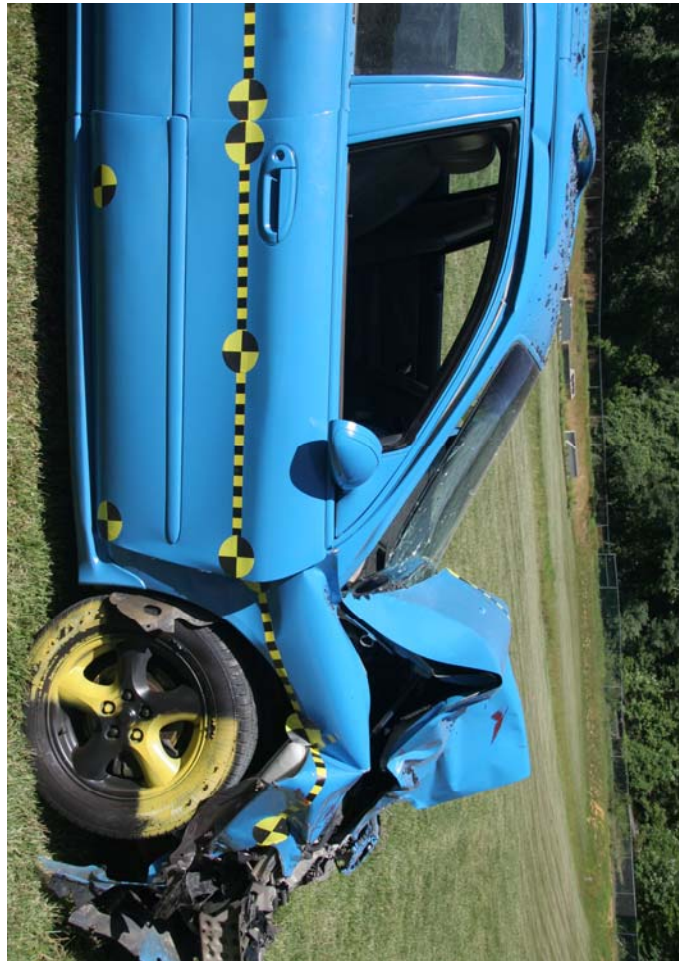
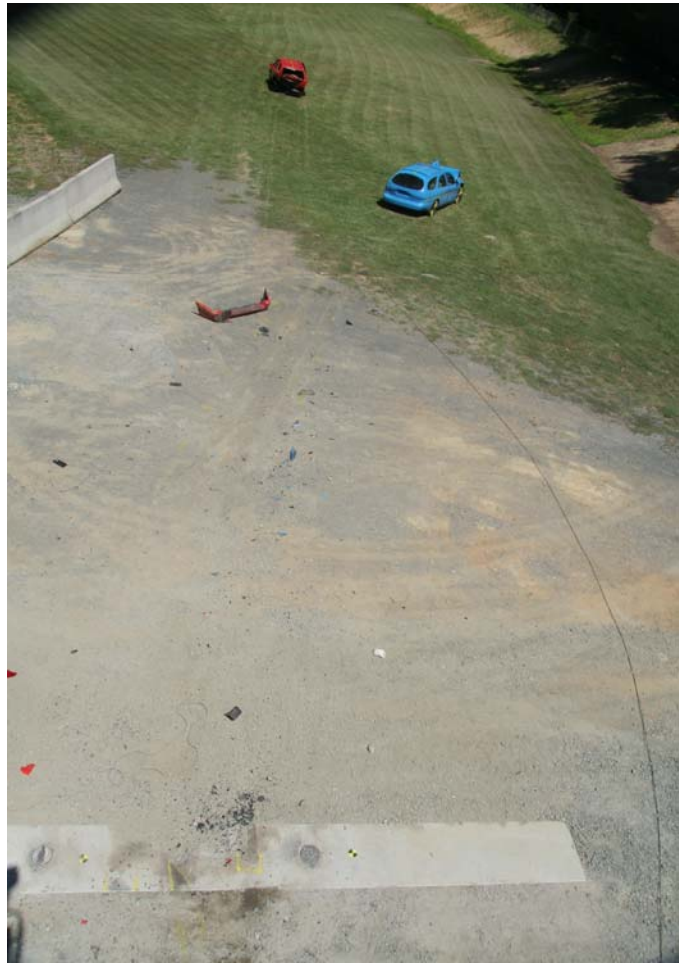

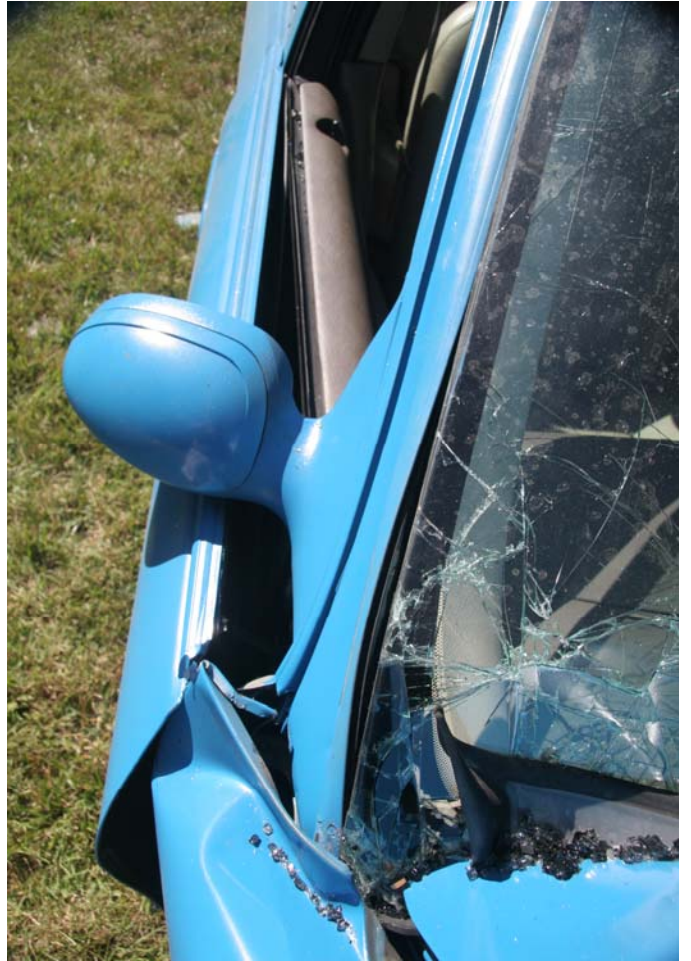
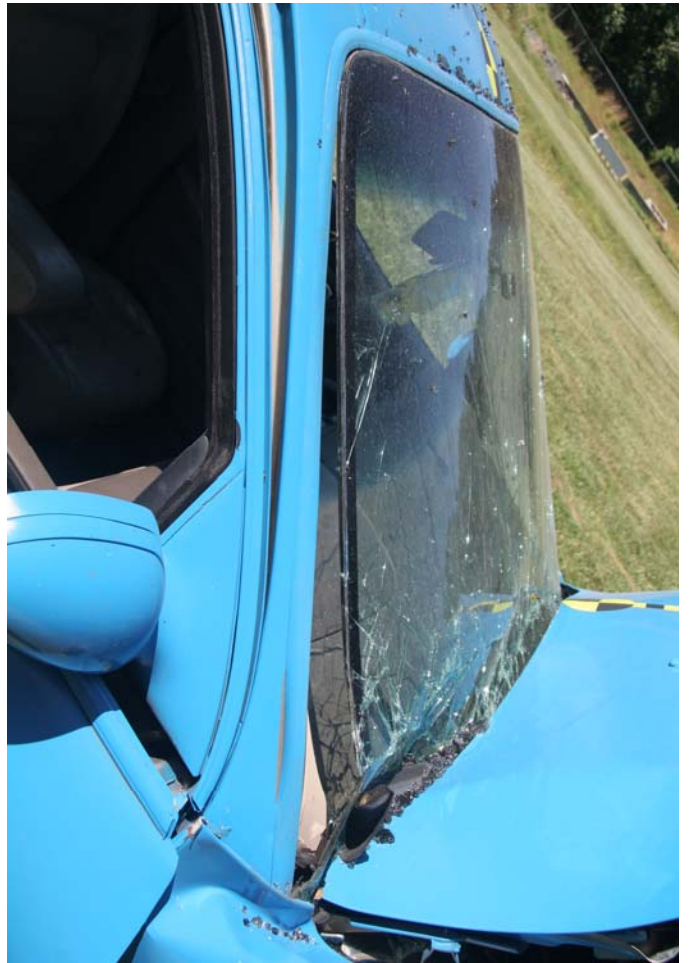



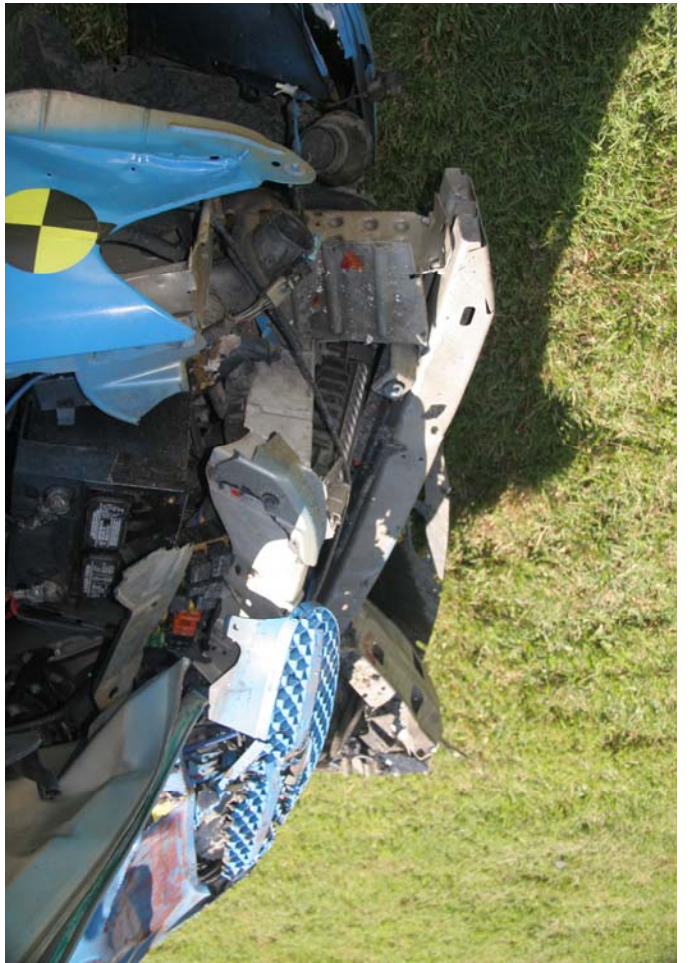



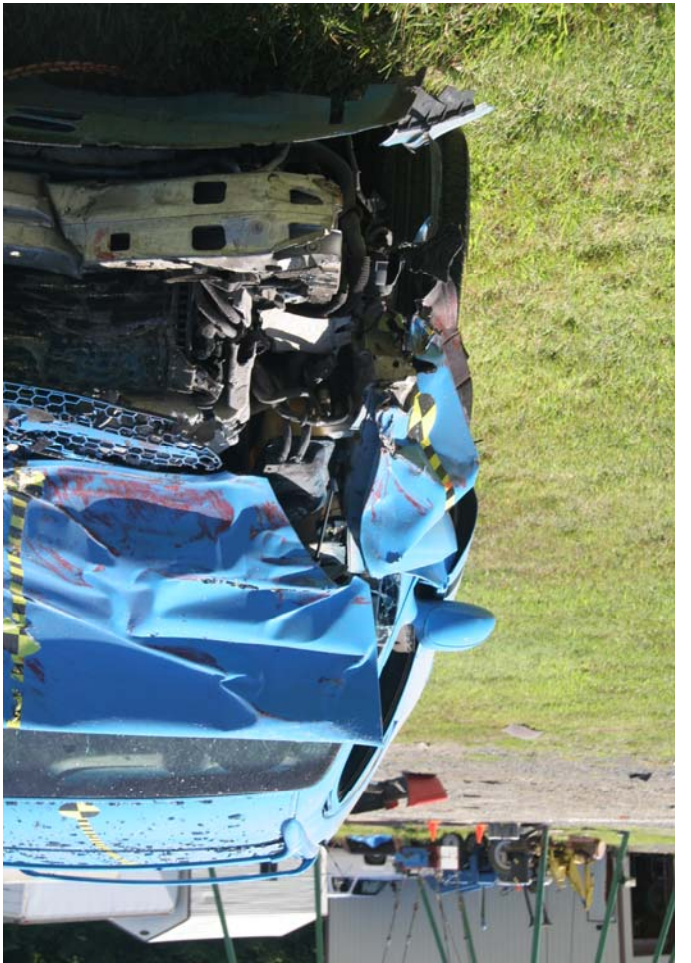



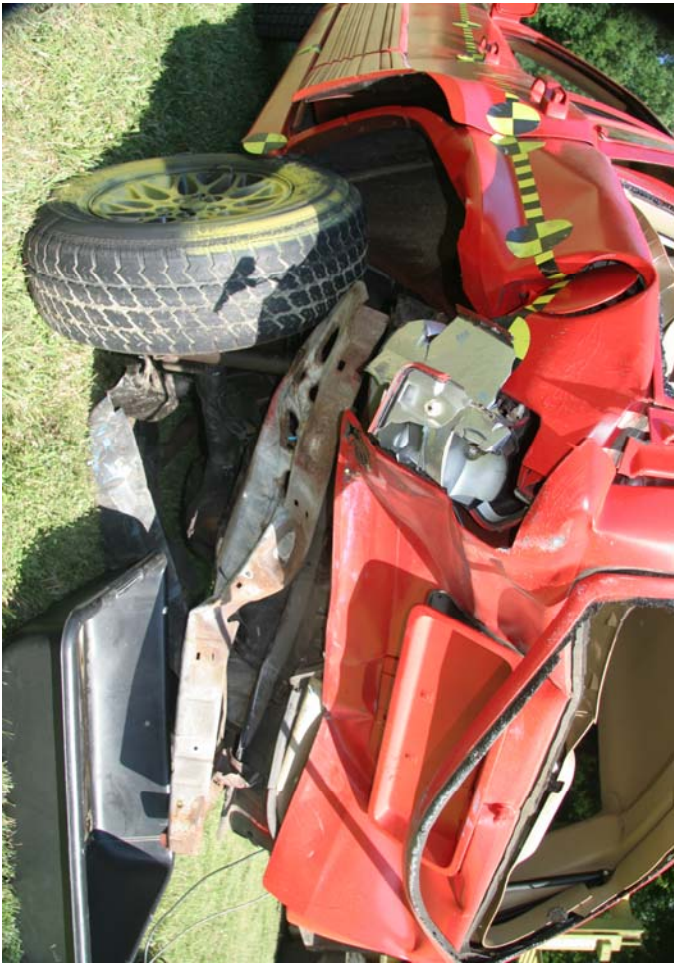
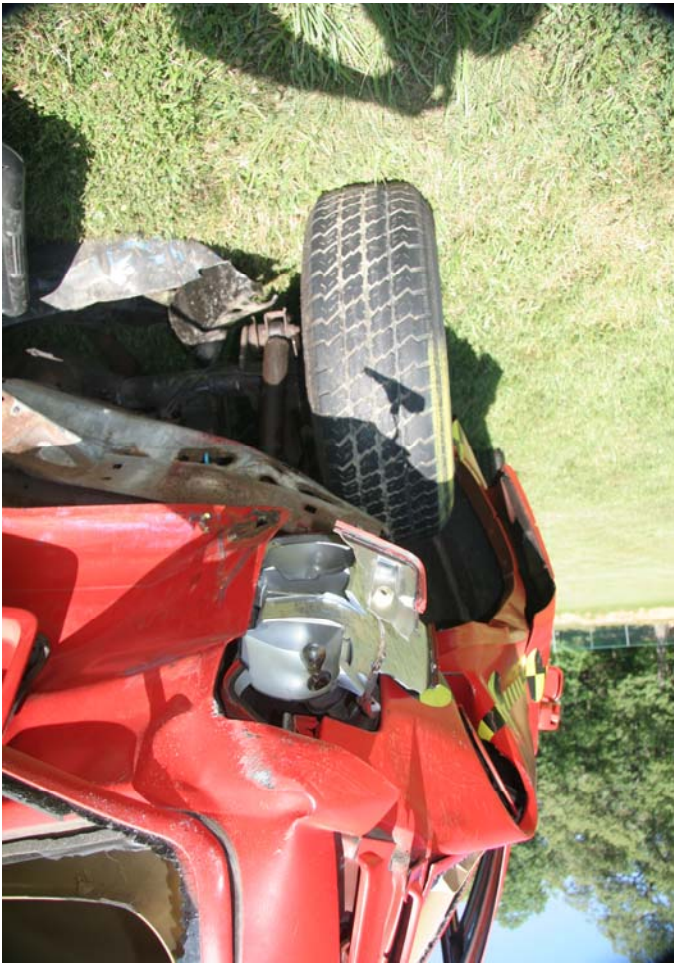





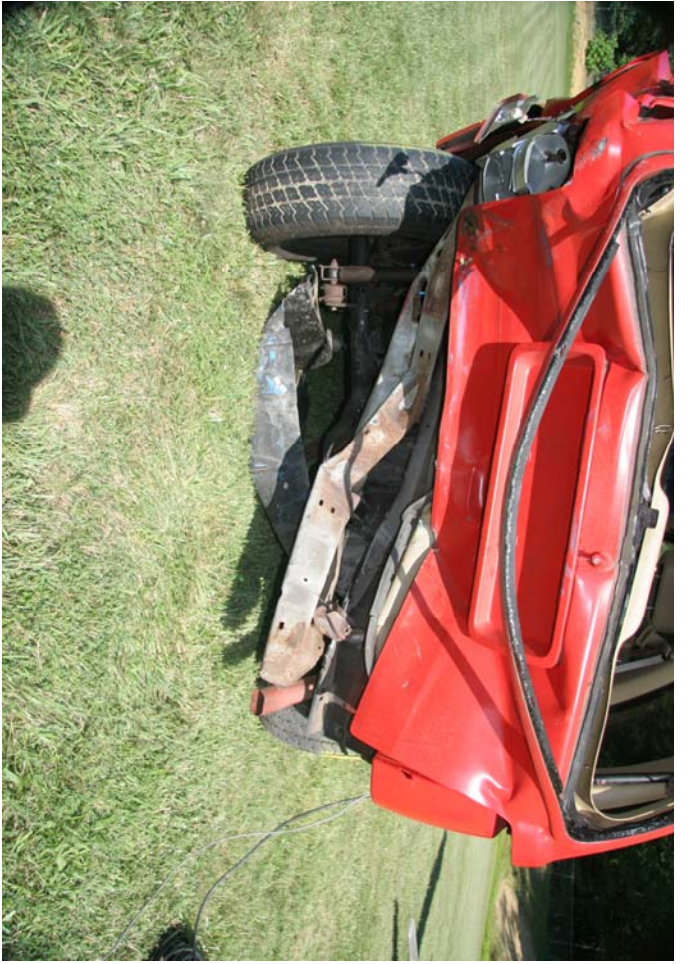

APPENDIX B

ACCELEROMETER DATA TRACES

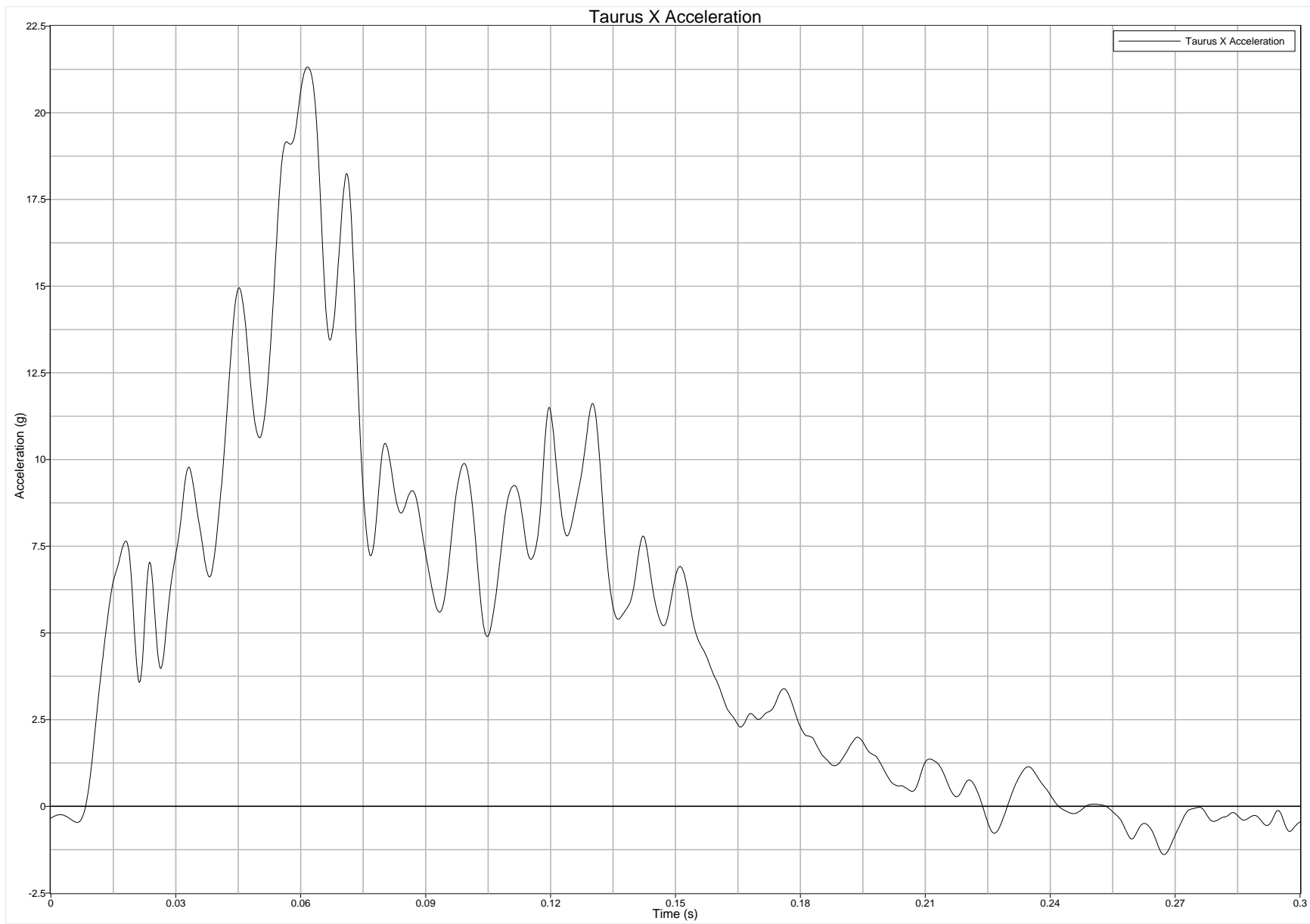

Taurus X Velocity

Taurus X Velocity

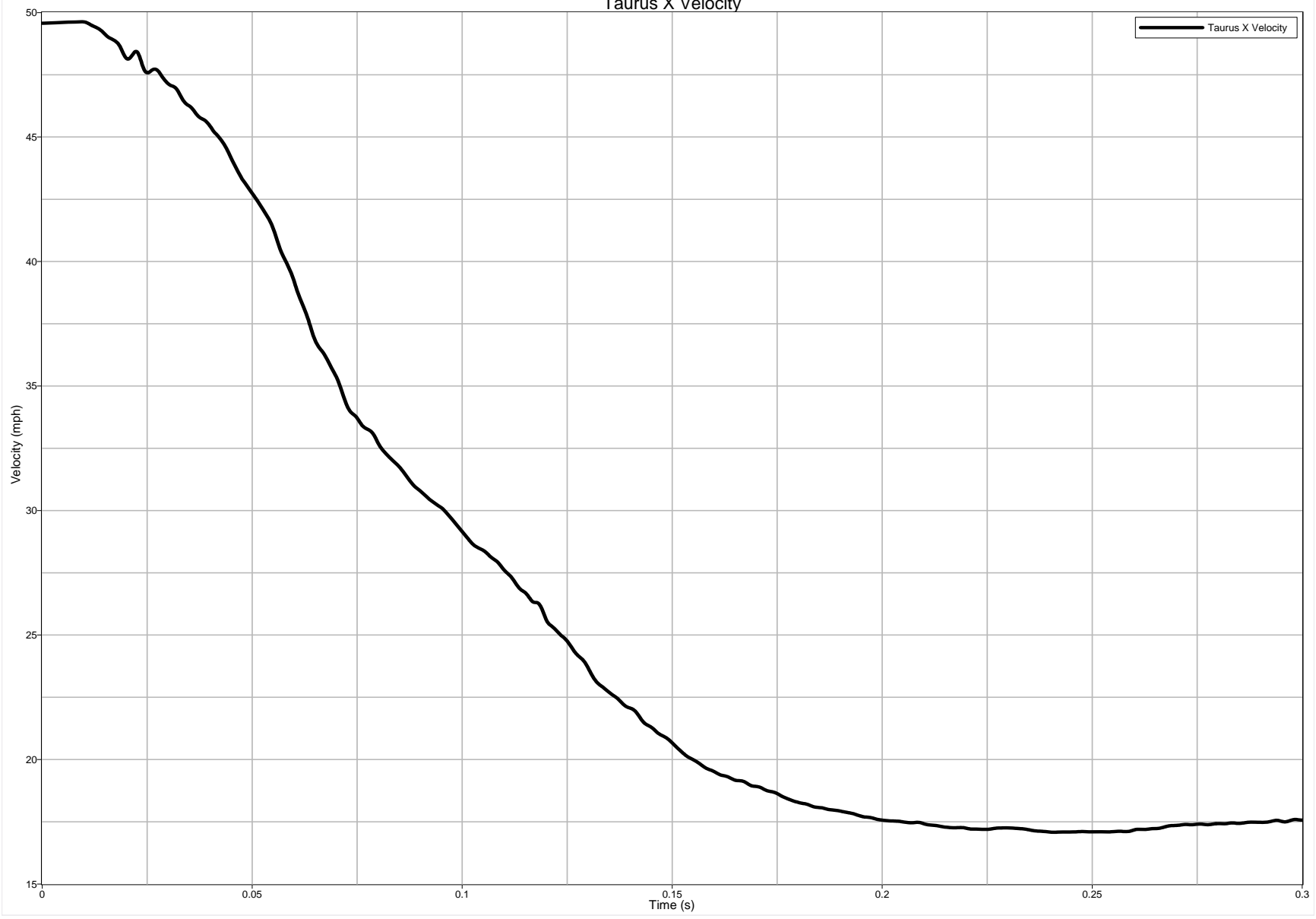

Taurus Y Acceleration

Taurus Y Acceleration

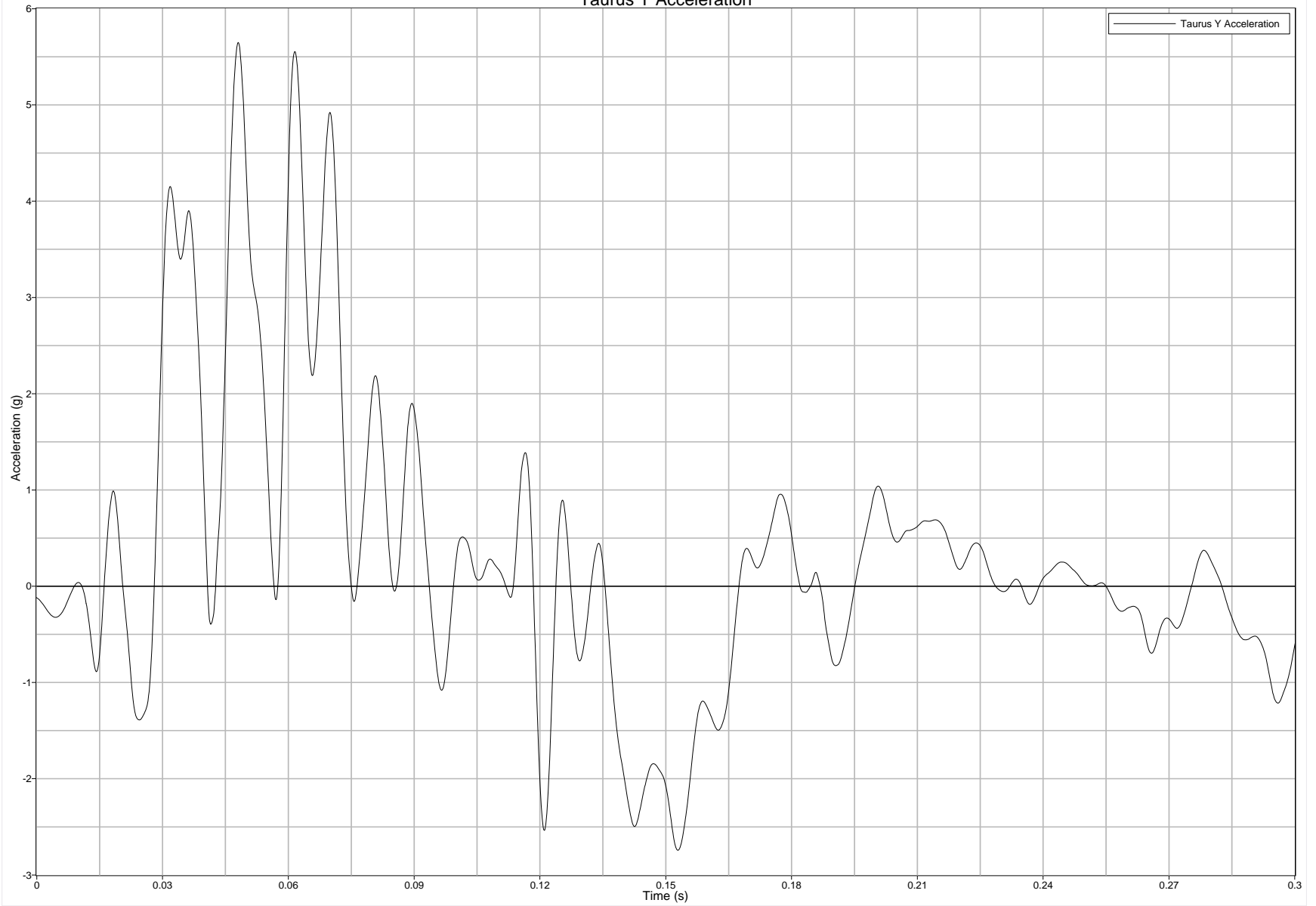

Taurus Y Velocity

Taurus Y Velocity

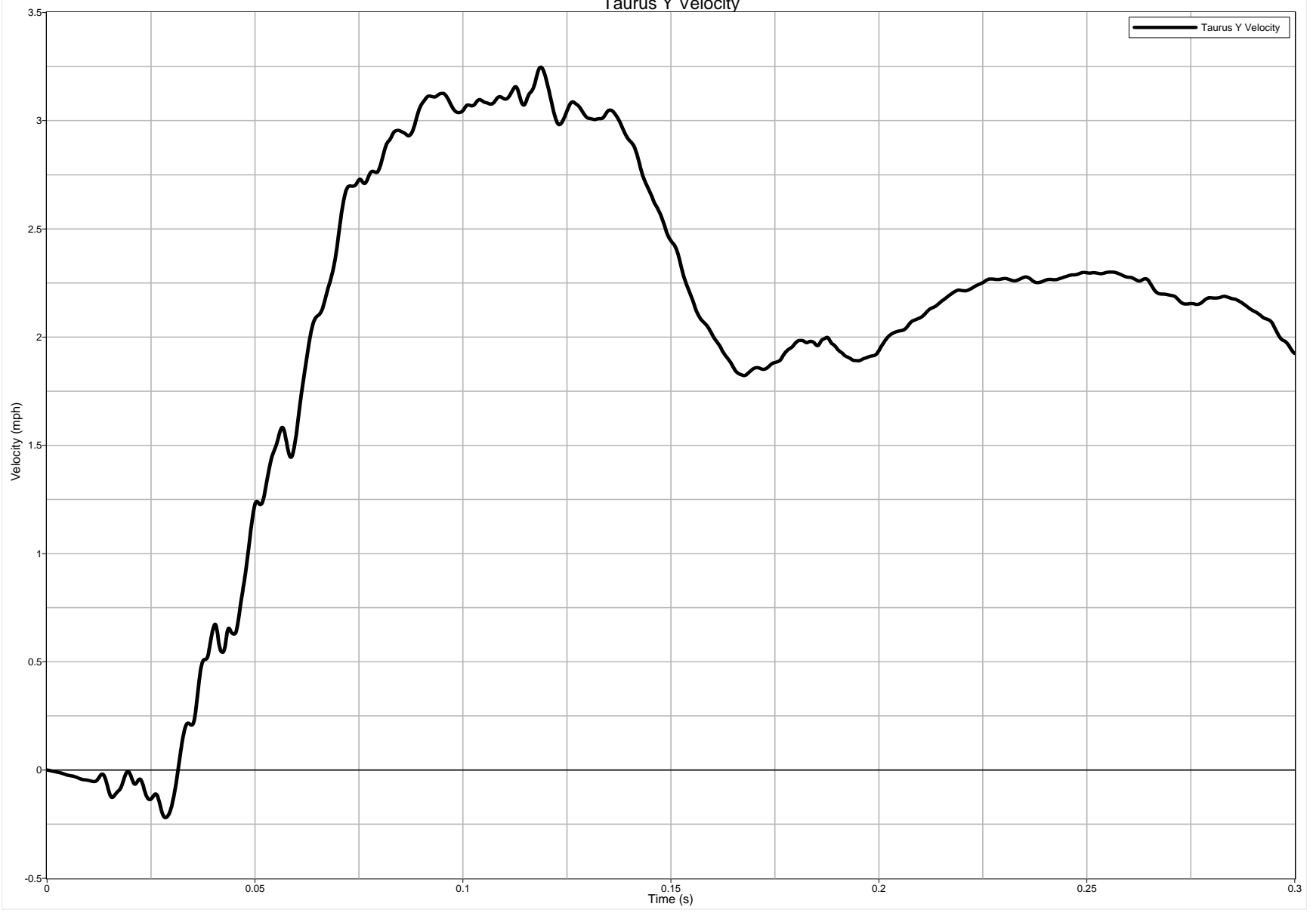

Taurus Z Acceleration

Taurus Z Acceleration

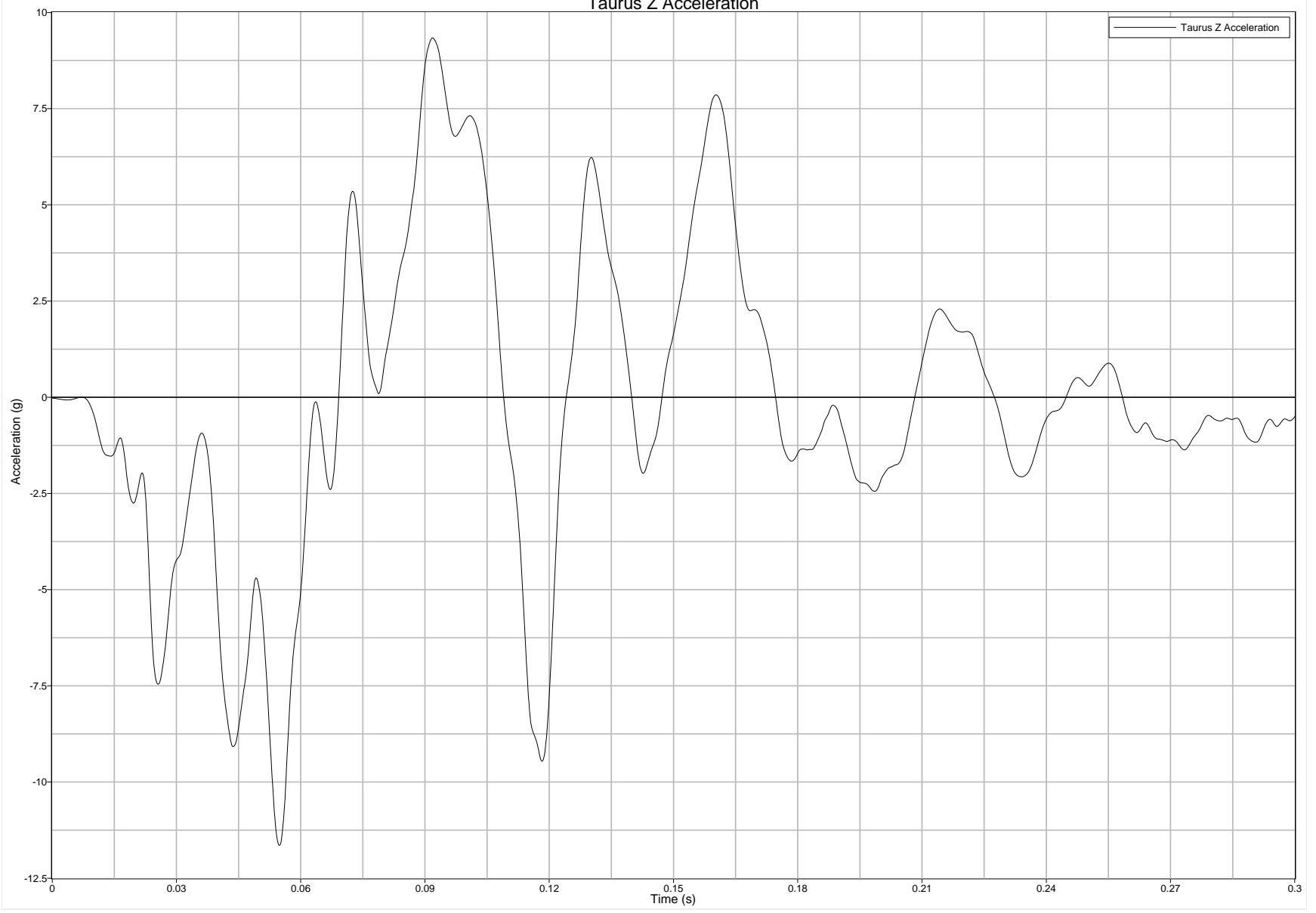

Taurus Roll Rate

Taurus Roll Rate

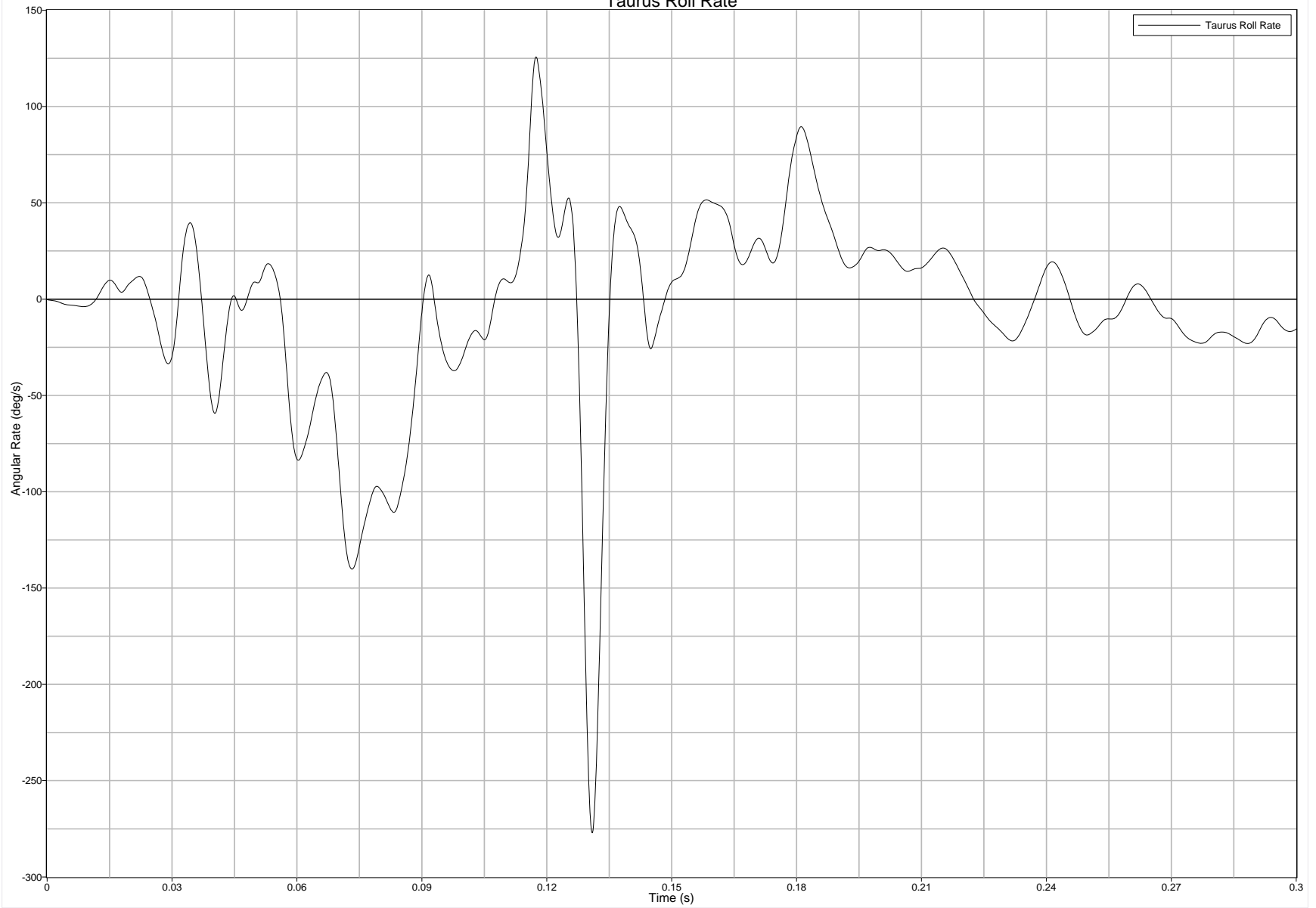

Taurus Pitch Rate

Taurus Pitch Rate

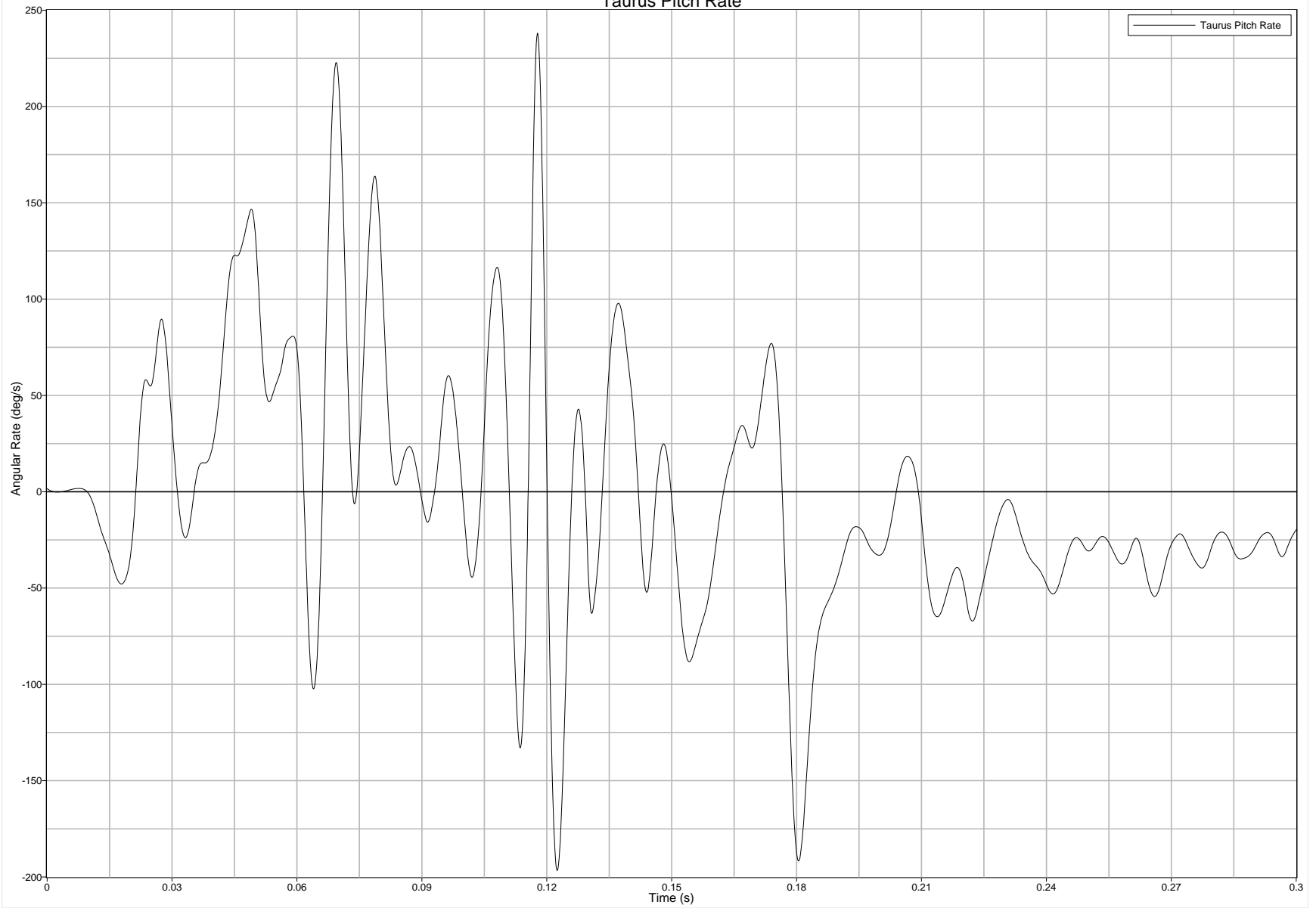

Taurus Yaw Rate

Taurus Yaw Rate

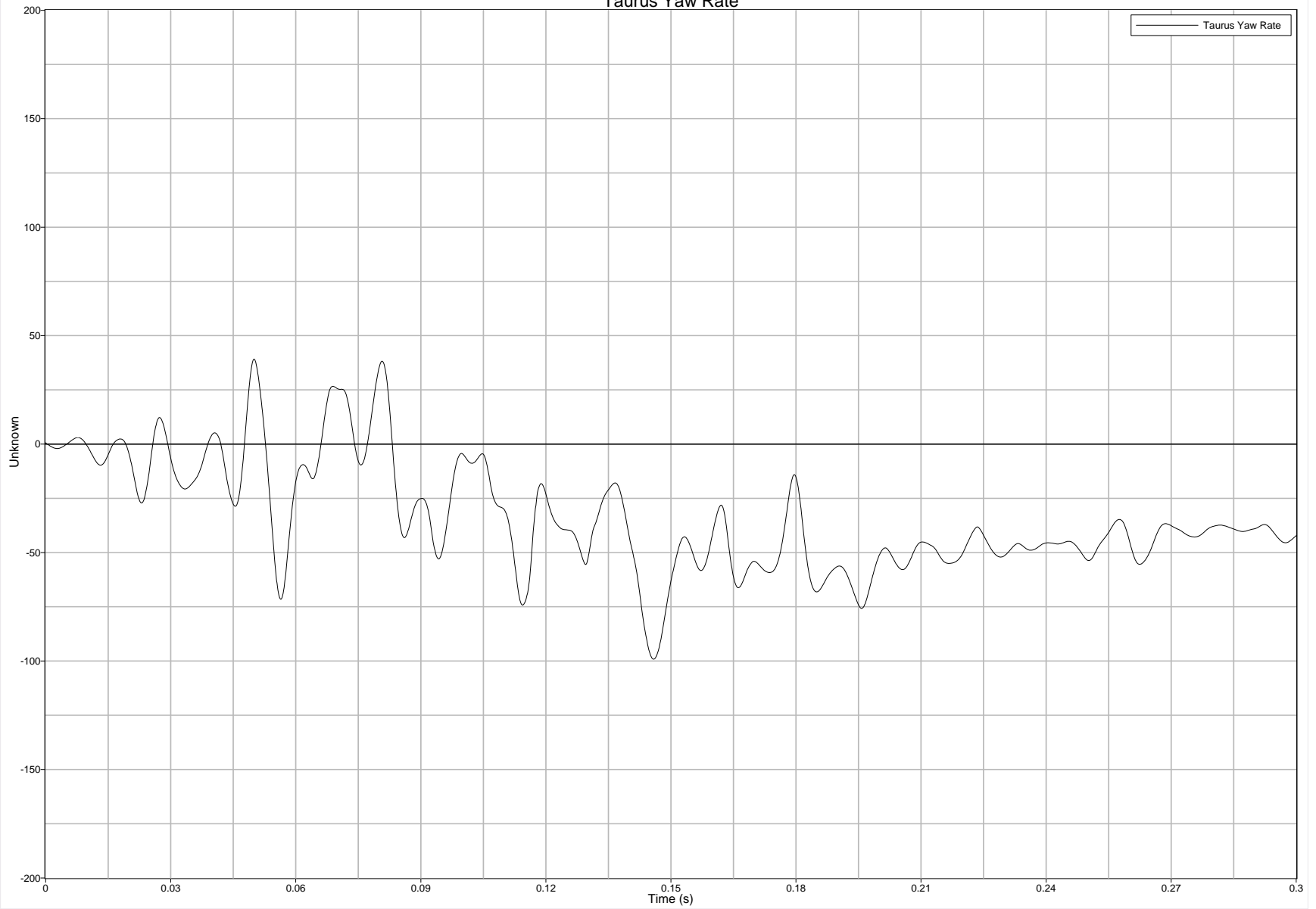

Taurus X Acceleration Redundant

Taurus X Acceleration Redundant

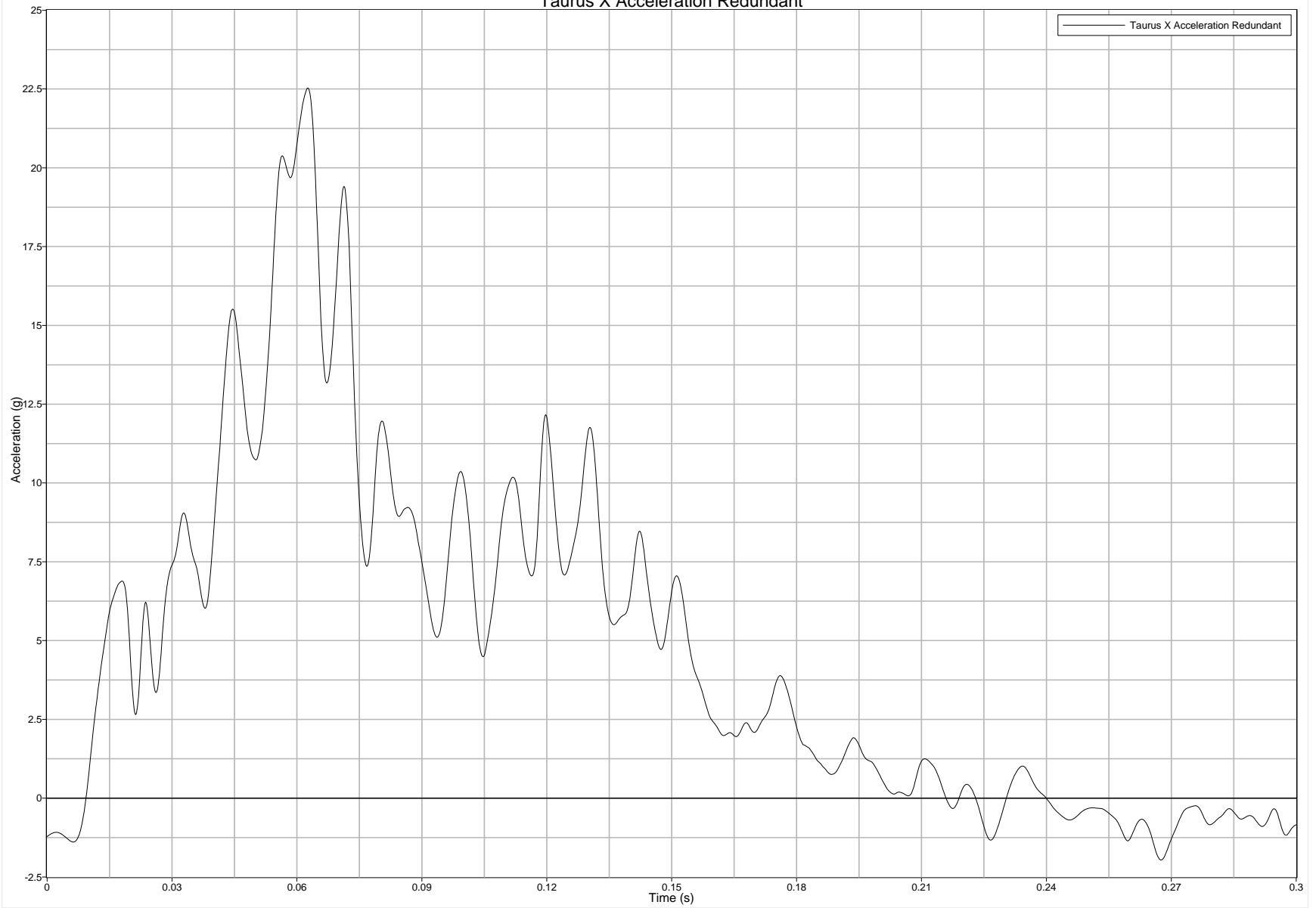

Taurus Y Acceleration Redundant

Taurus Y Acceleration Redundant

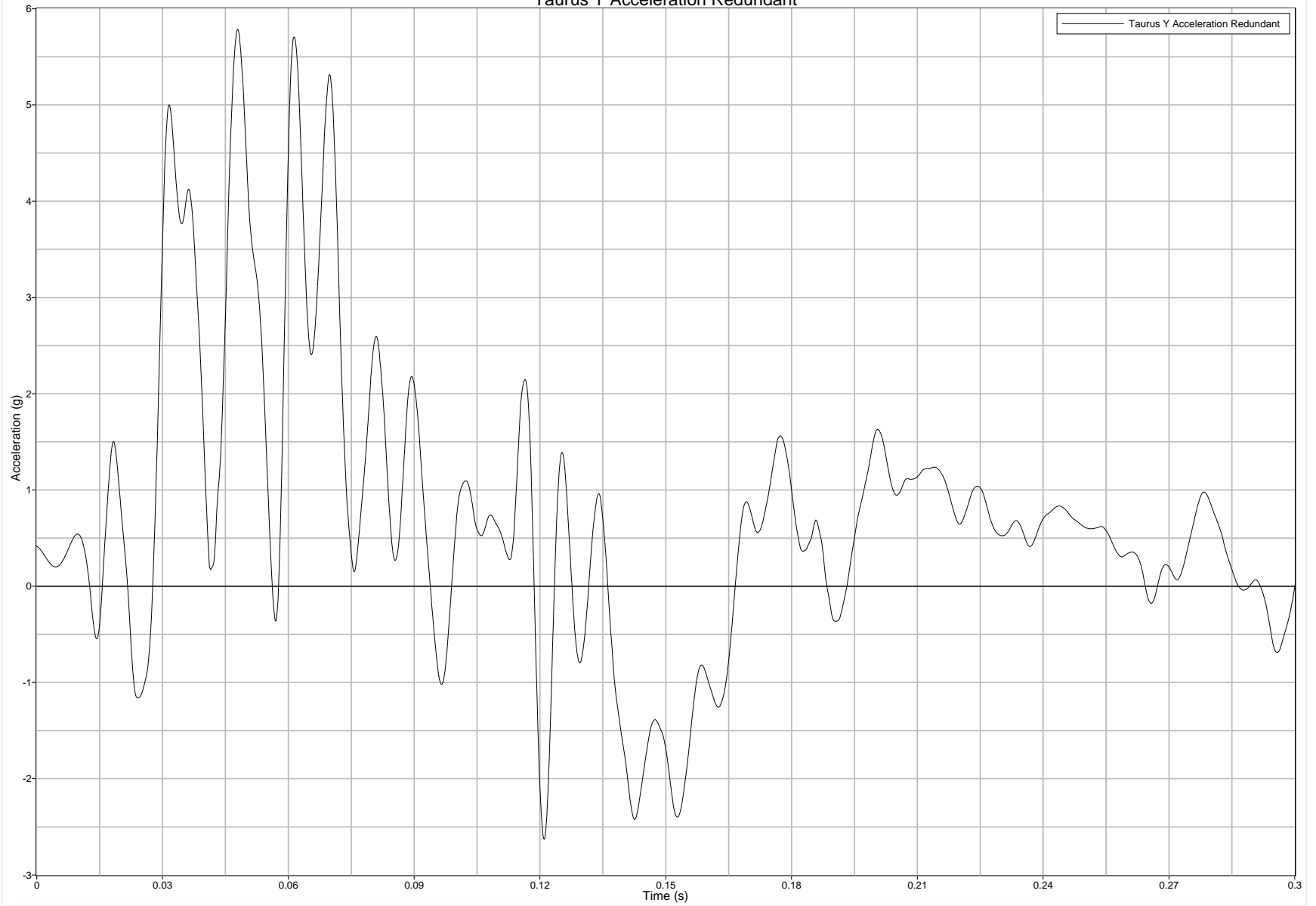

Taurus Z Acceleration Redundant

Taurus Z Acceleration Redundant

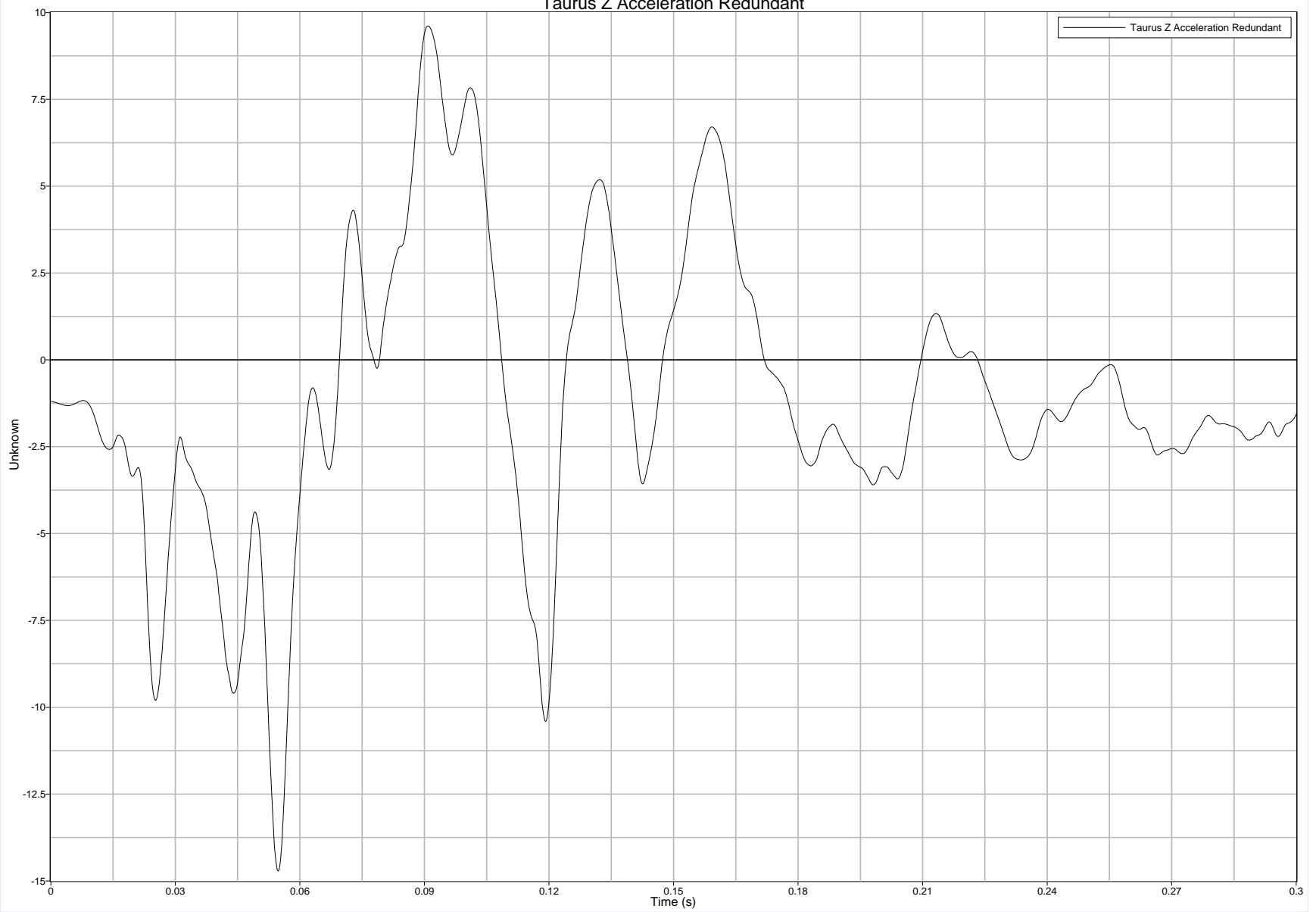

Jeep X Acceleration

Jeep X Acceleration

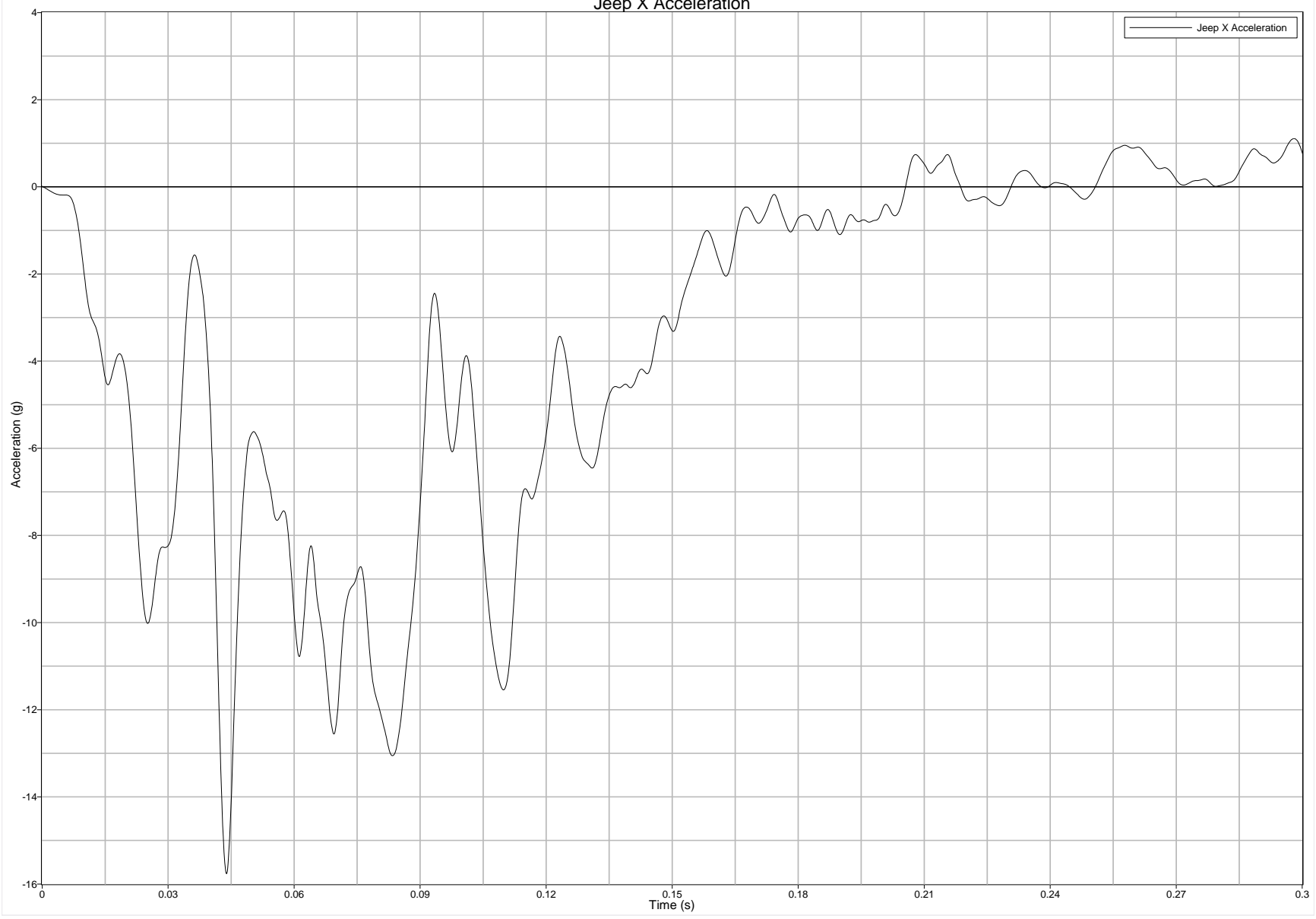

Jeep X Velocity

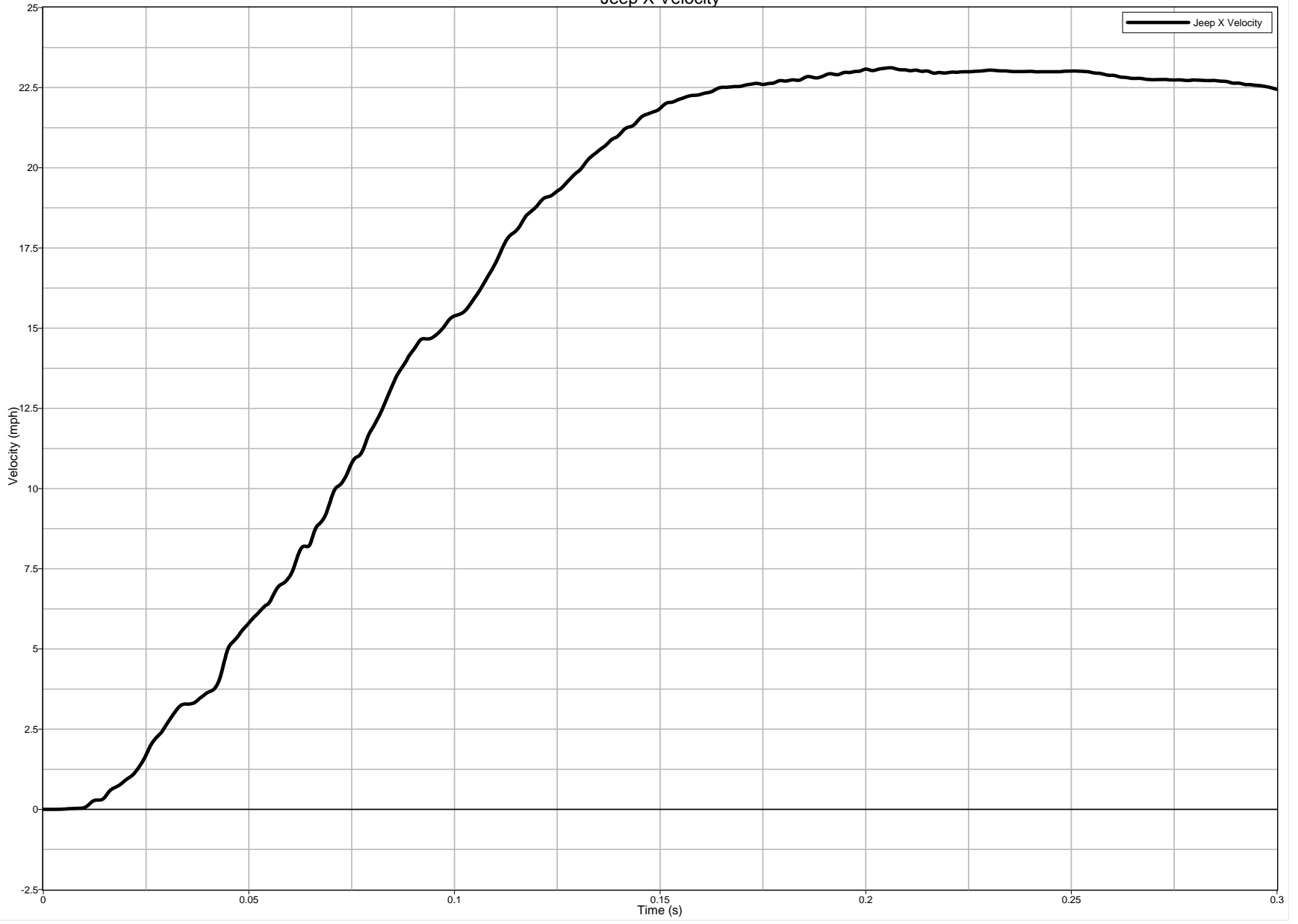

Jeep Y Acceleration

Jeep Y Acceleration

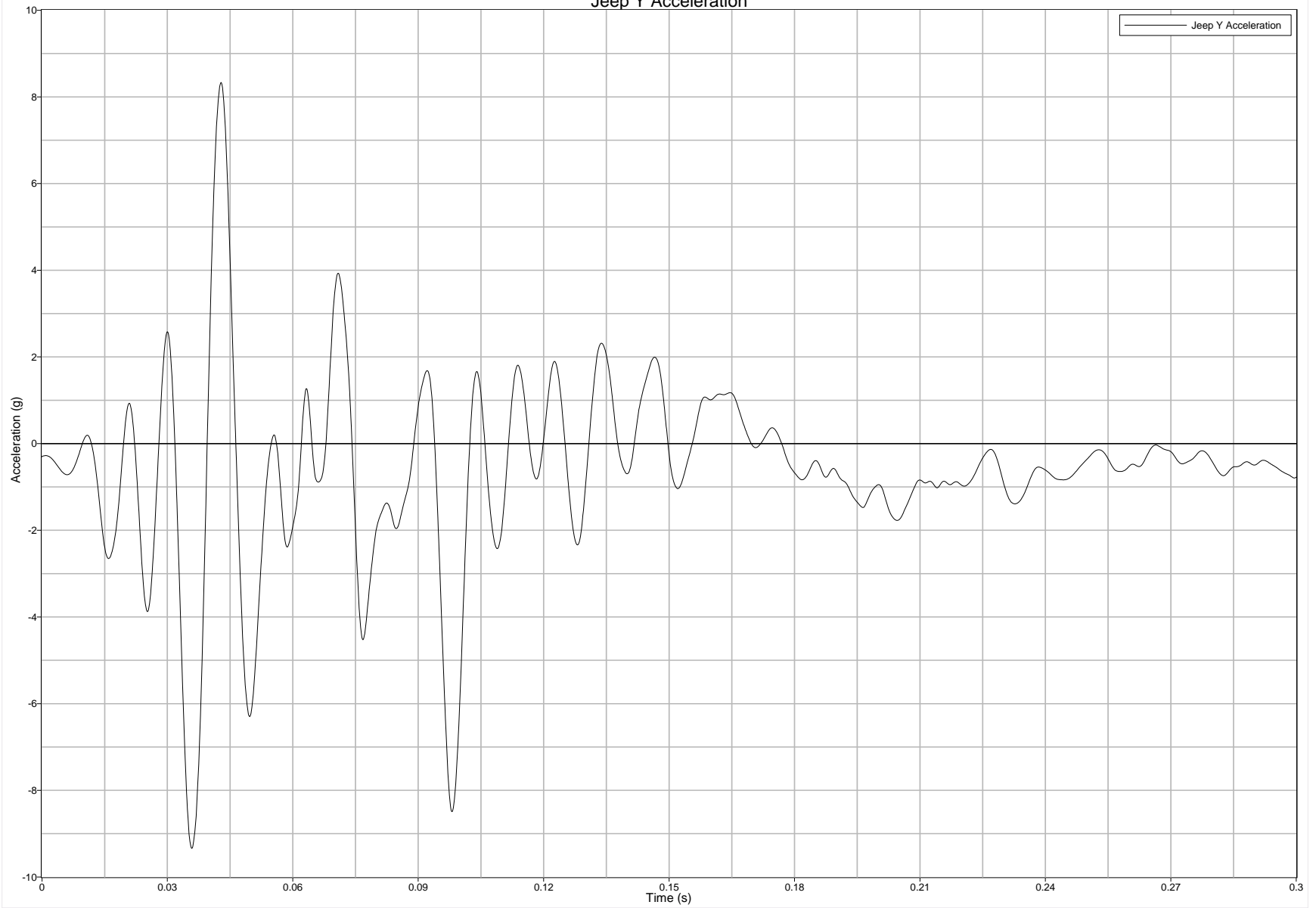

Jeep Y Velocity

Jeep Y Velocity

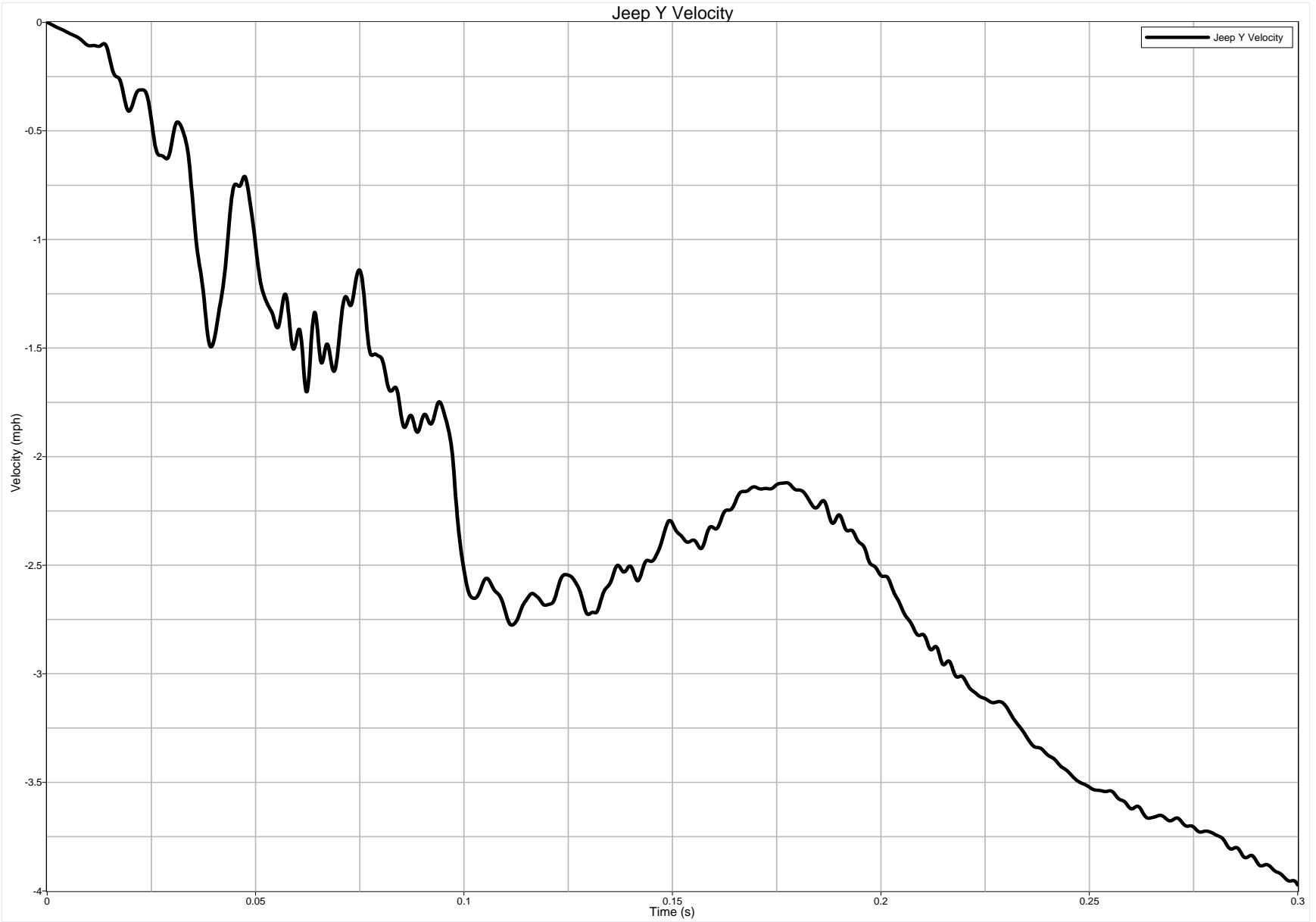

Jeep Z Acceleration

Jeep Z Acceleration

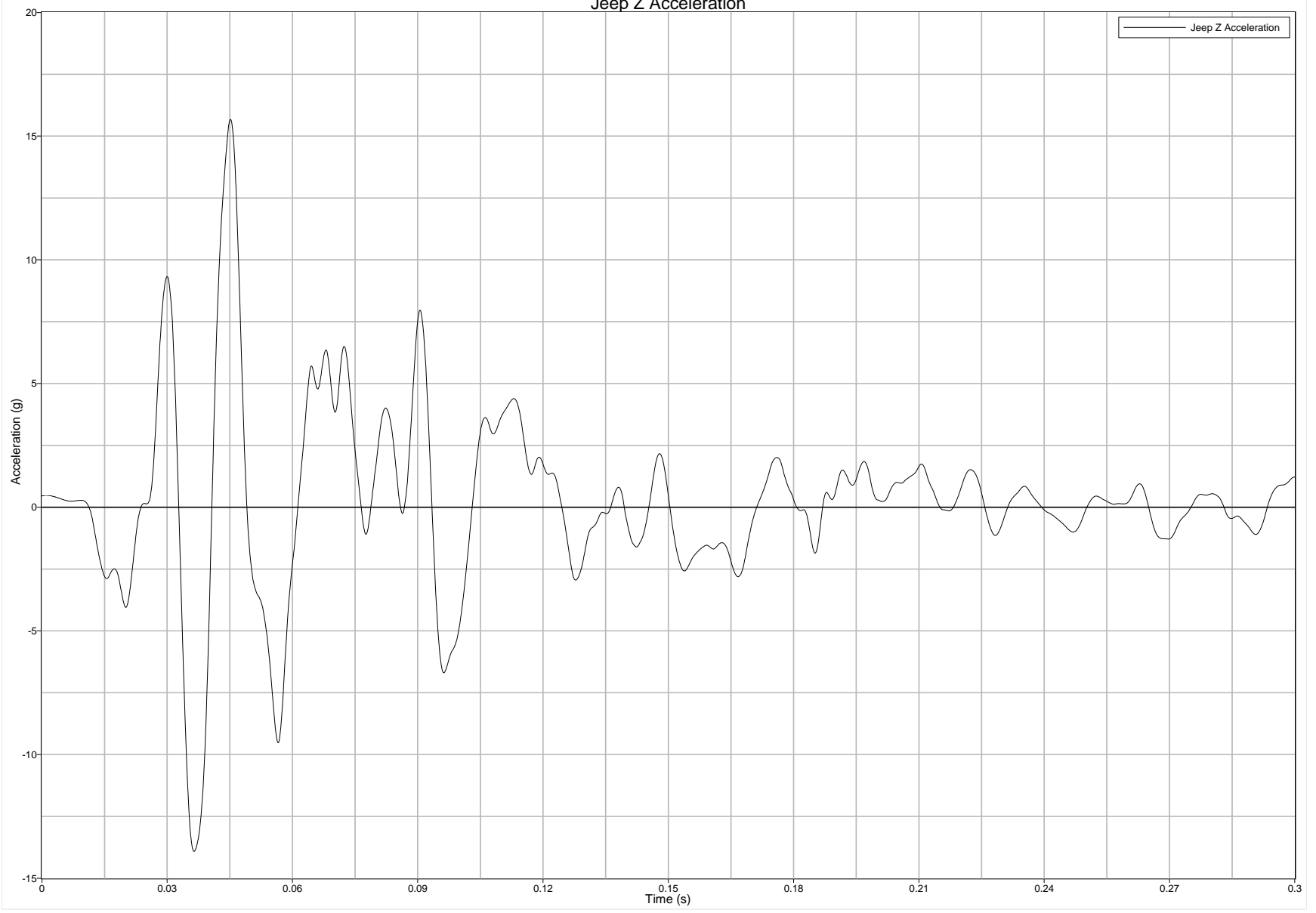

Jeep Roll Rate

Jeep Roll Rate

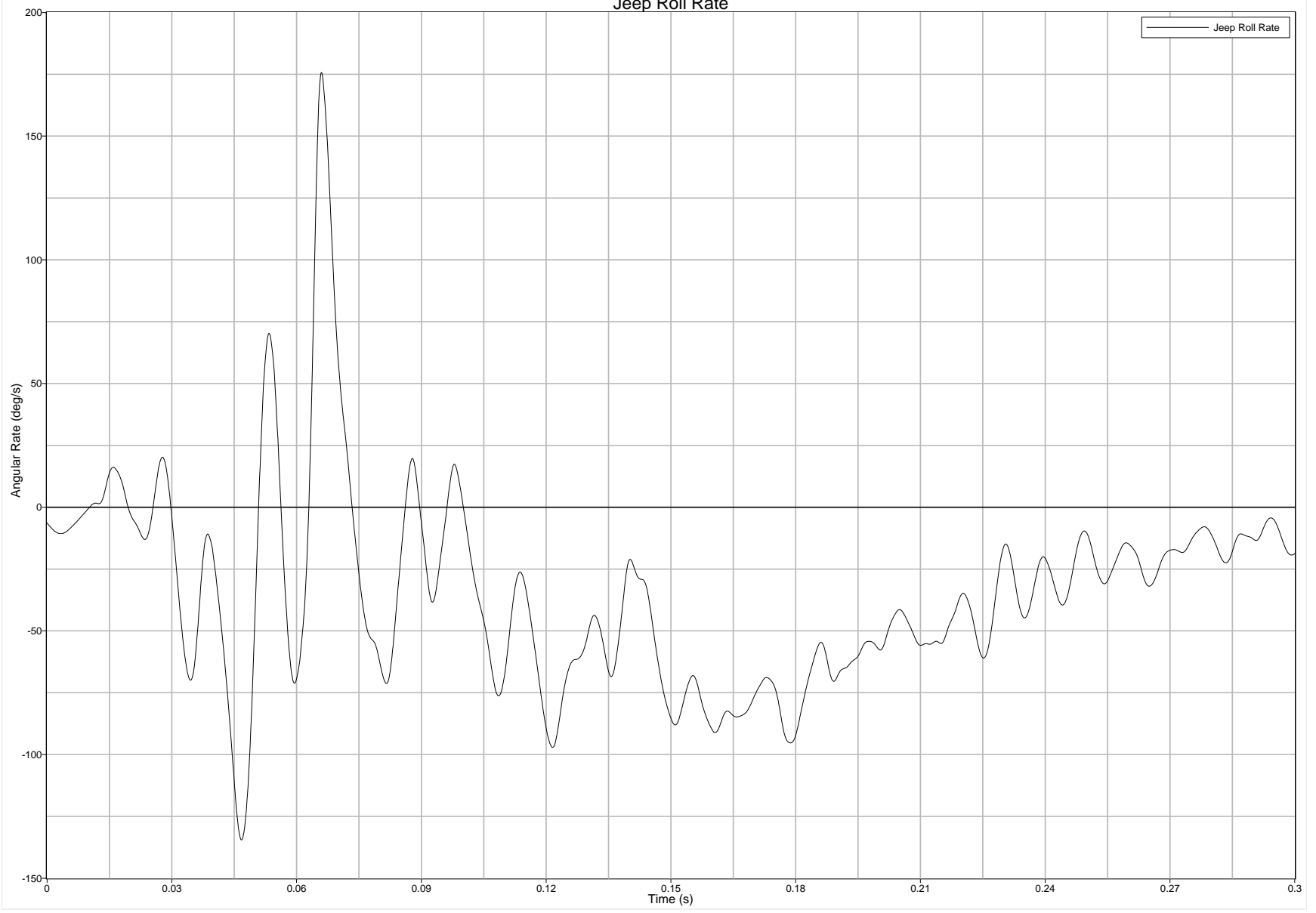

Jeep Pitch Rate

Jeep Pitch Rate

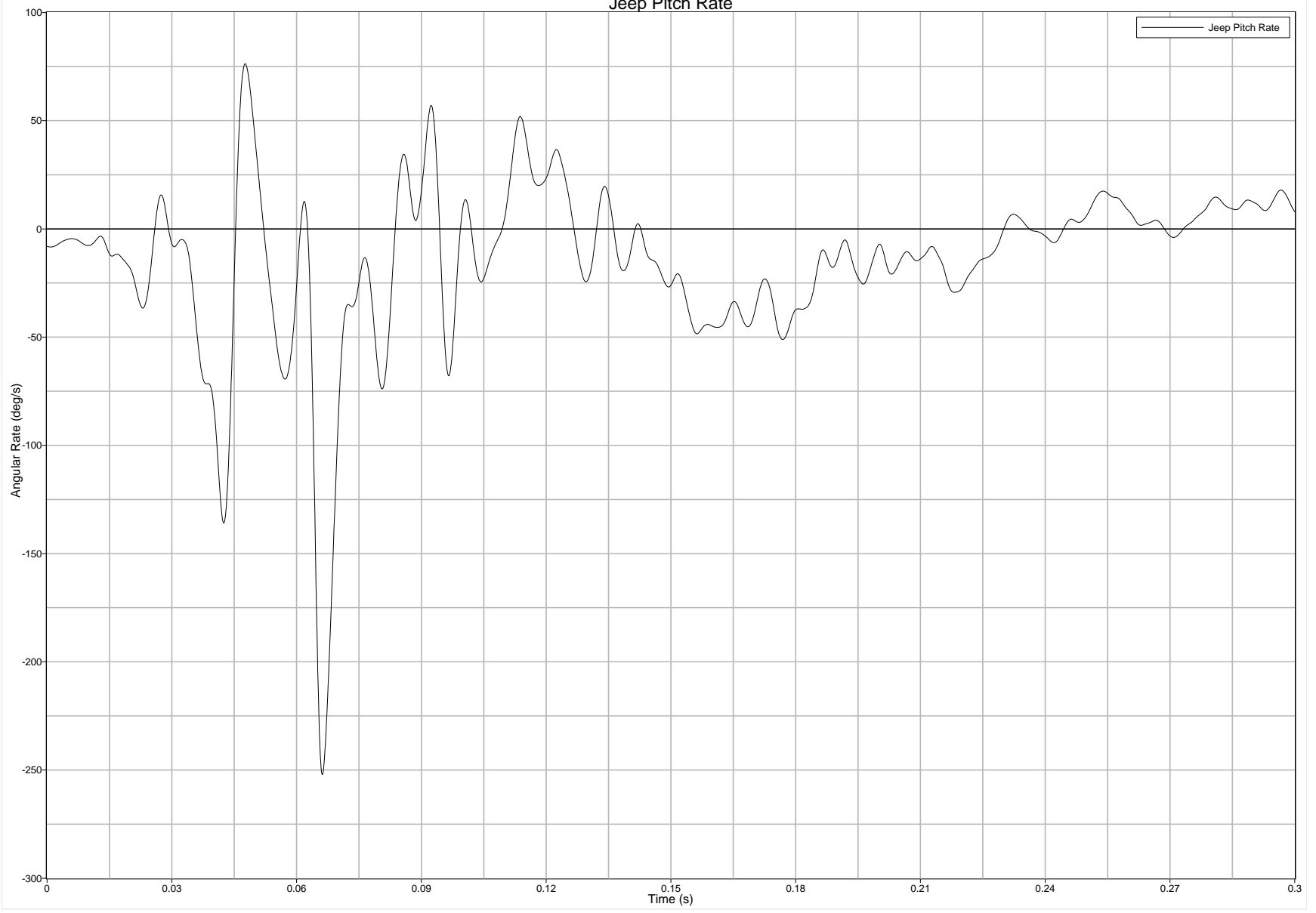

Jeep Pitch Rate

Jeep Pitch Rate

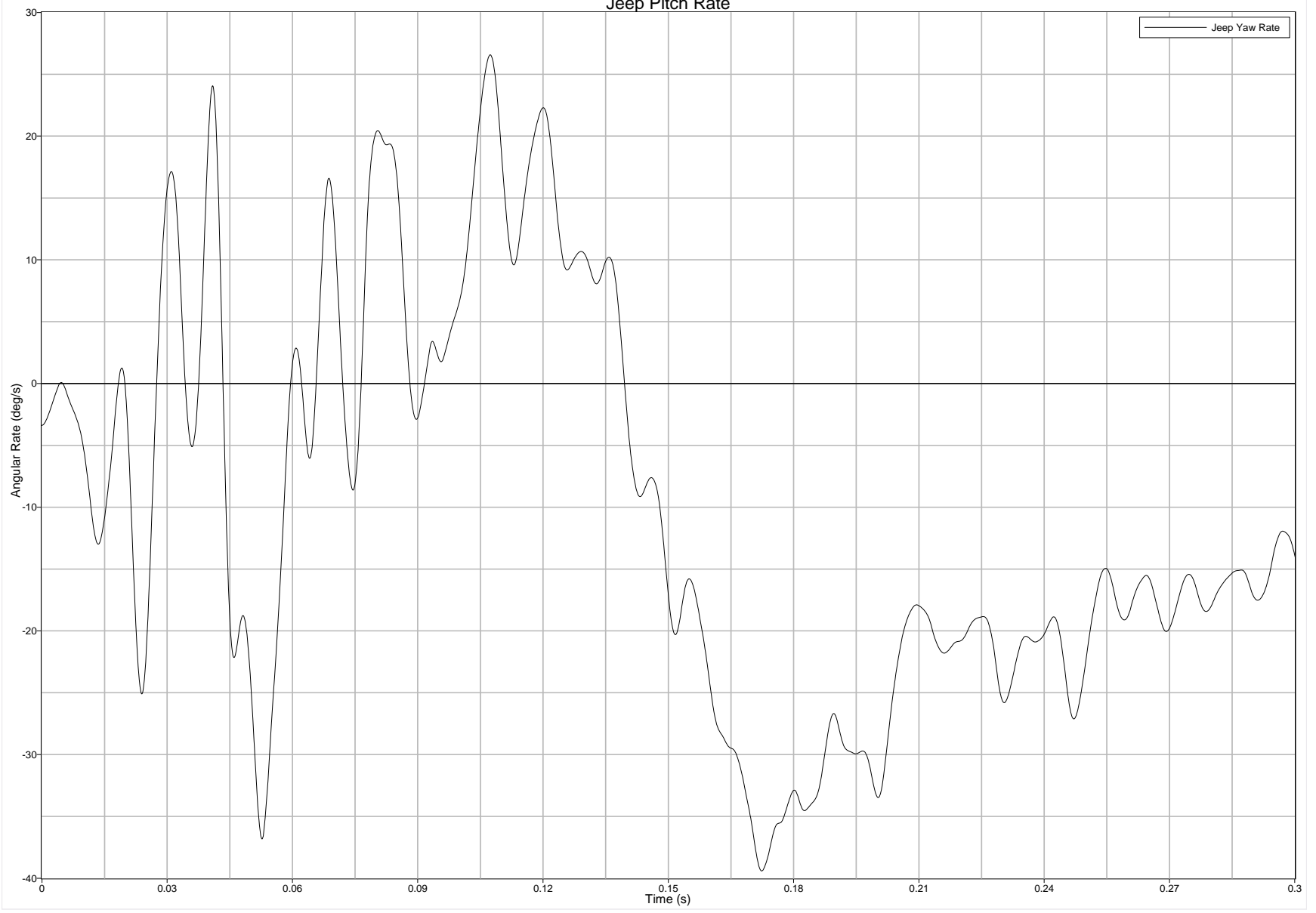

Jeep X Acceleration Redundant

Jeep X Acceleration Redundant

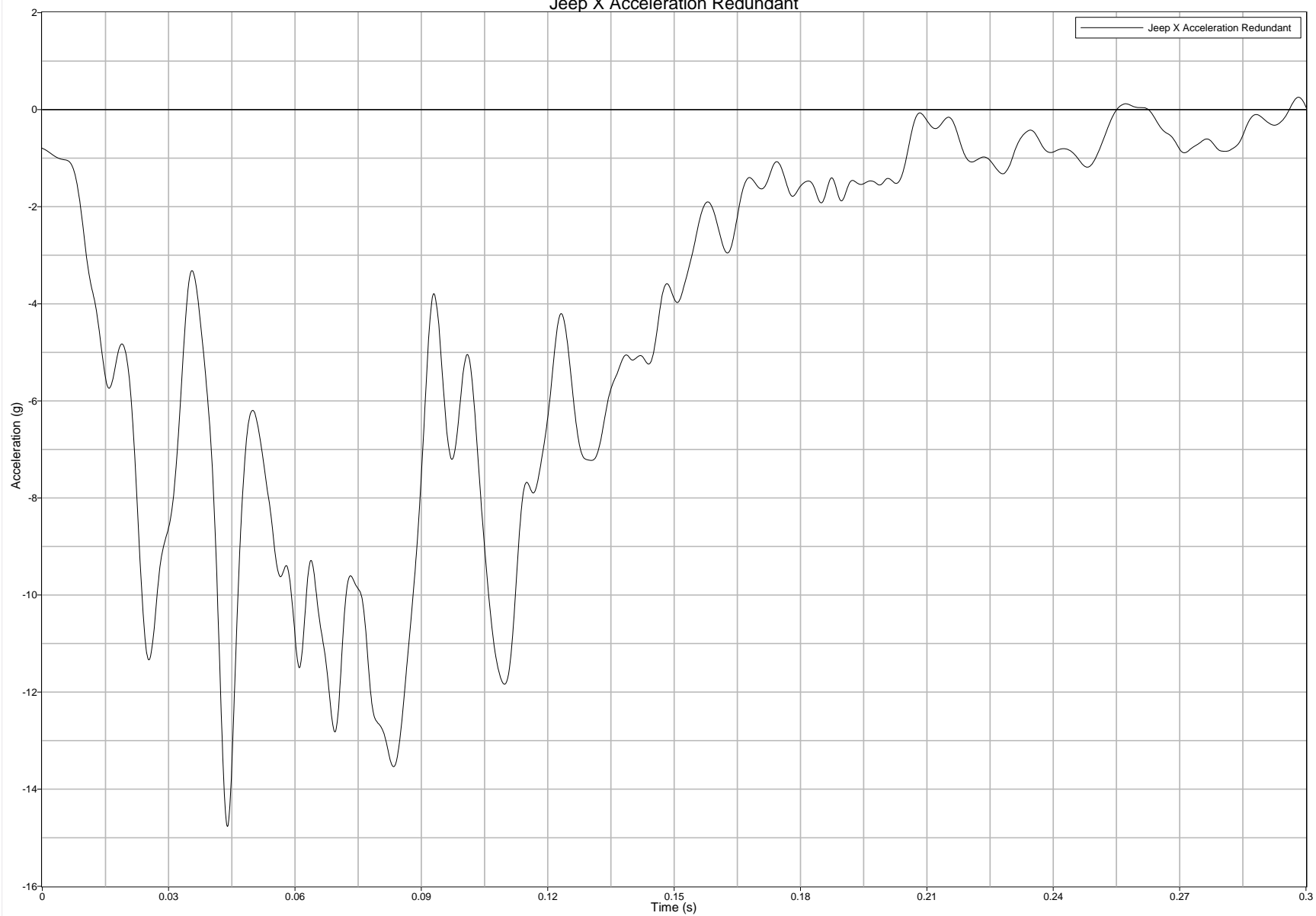

Jeep Y Acceleration Redundant

Jeep Y Acceleration Redundant

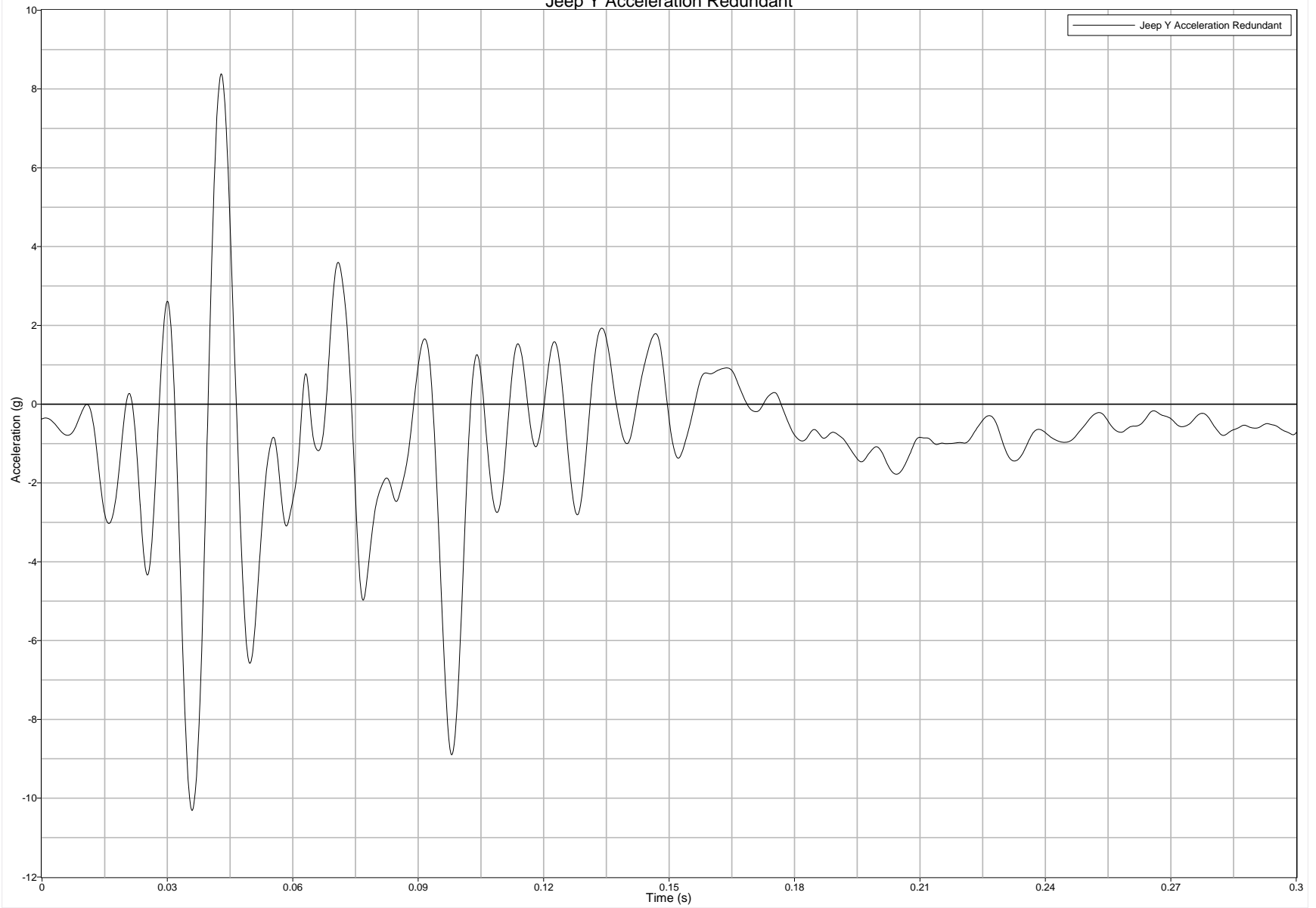

Jeep Z Acceleration Redundant

Jeep Z Acceleration Redundant

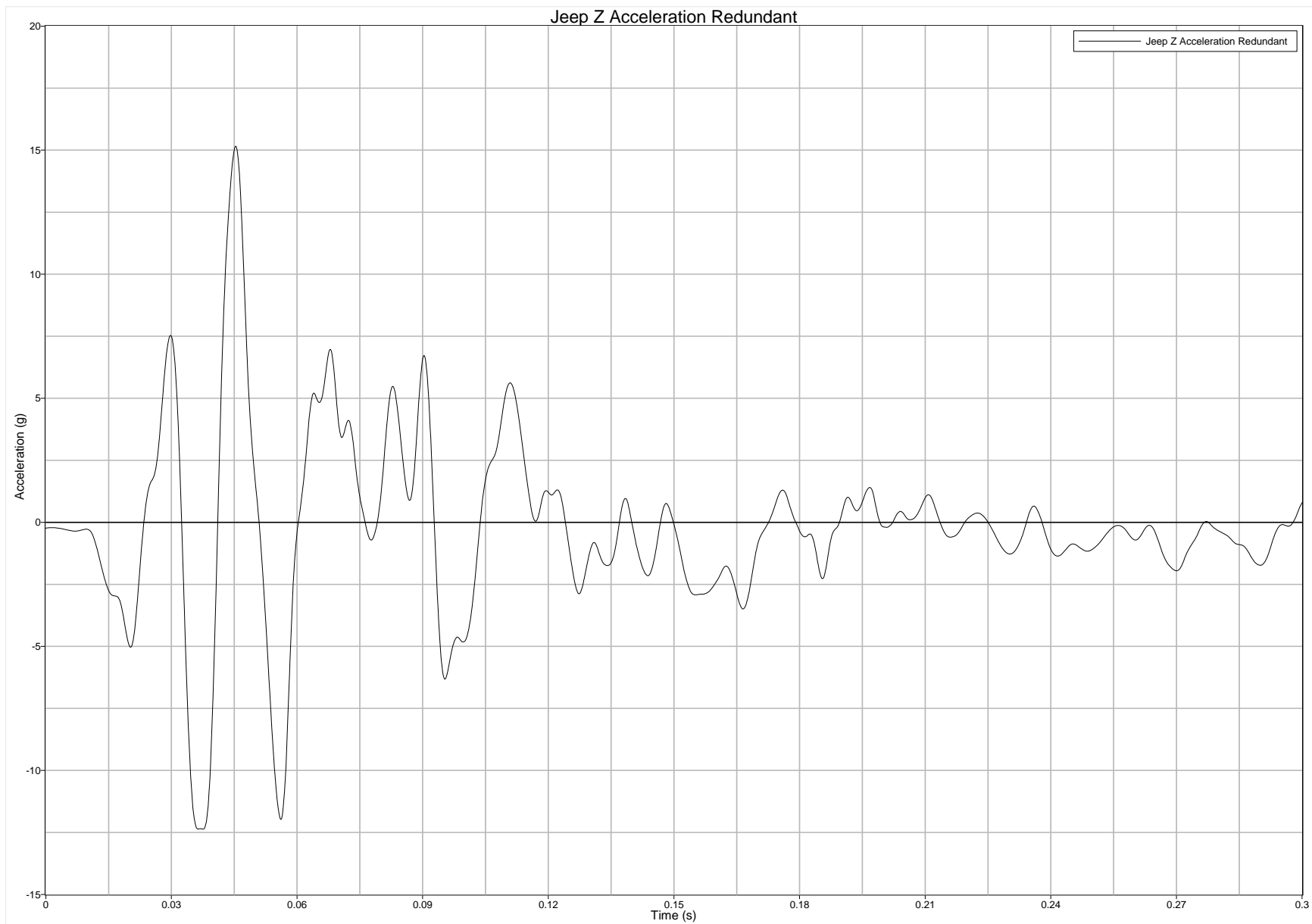

Jeep Roll Rate Redundant

Jeep Roll Rate Redundant

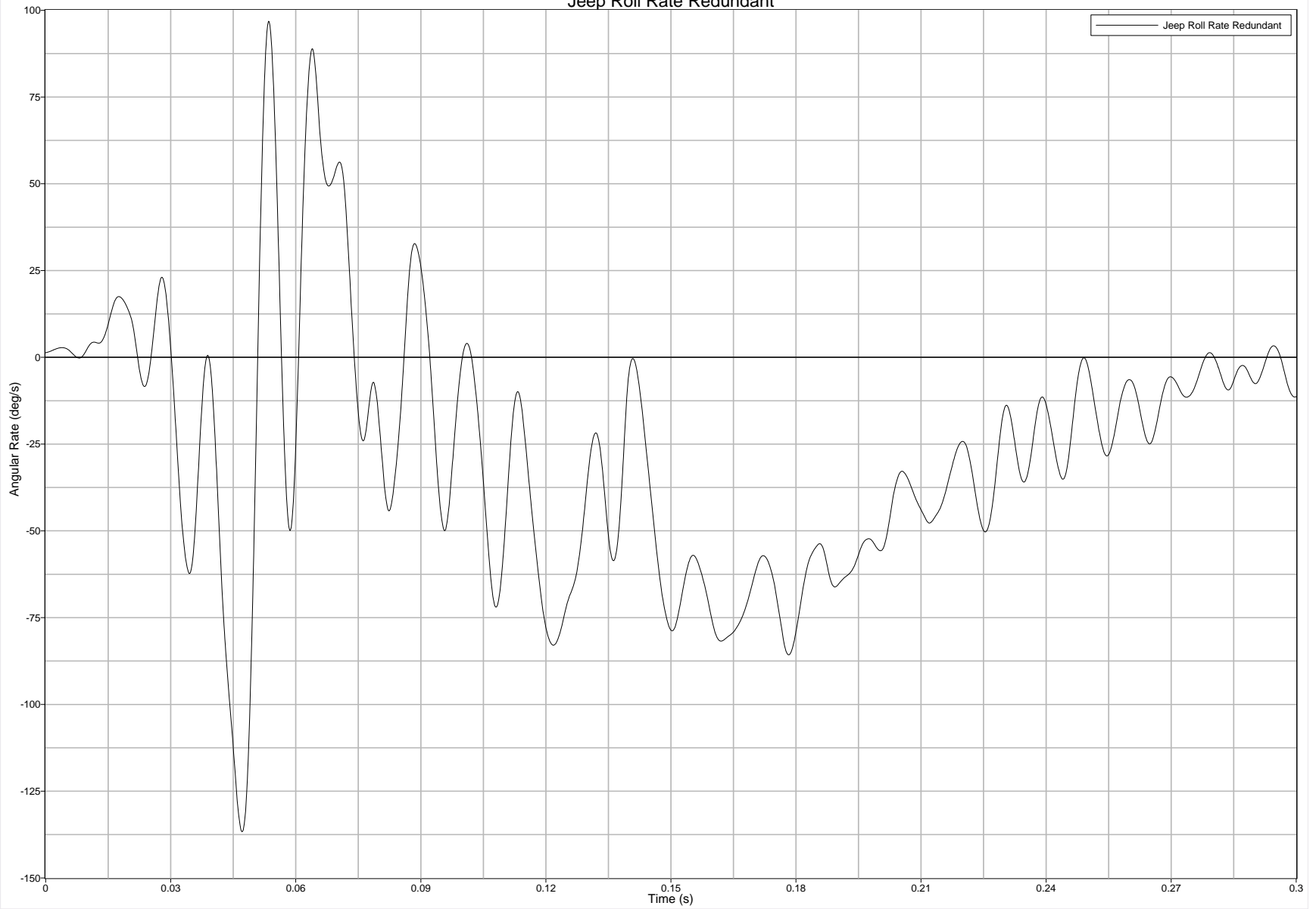

Jeep Pitch Rate Redundant

Jeep Pitch Rate Redundant

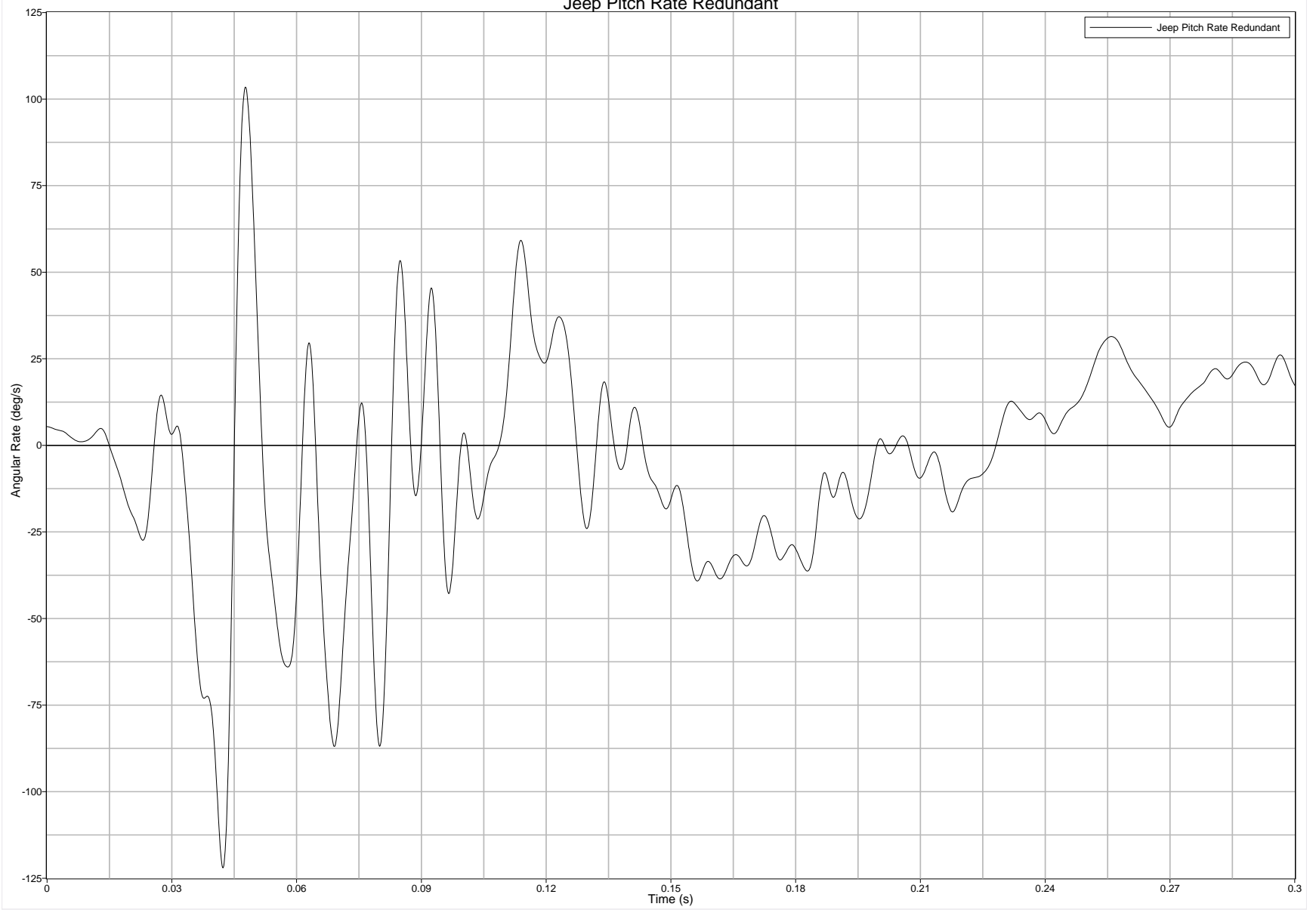

Jeep Yaw Rate Redundant

Jeep Yaw Rate Redundant

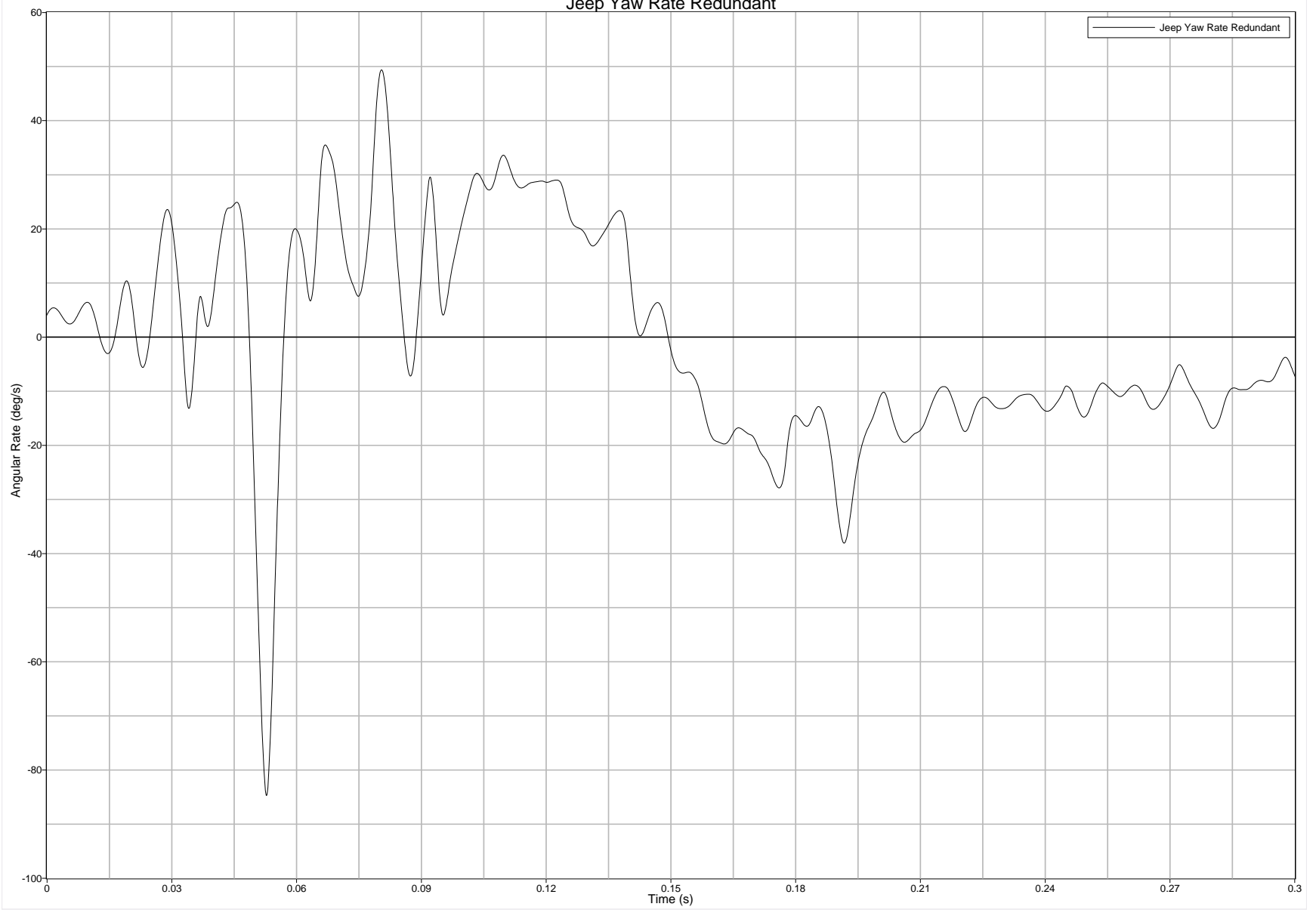

Scale in Feet:

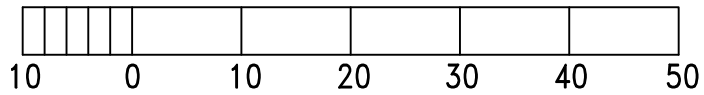

Accident Scene Evidence

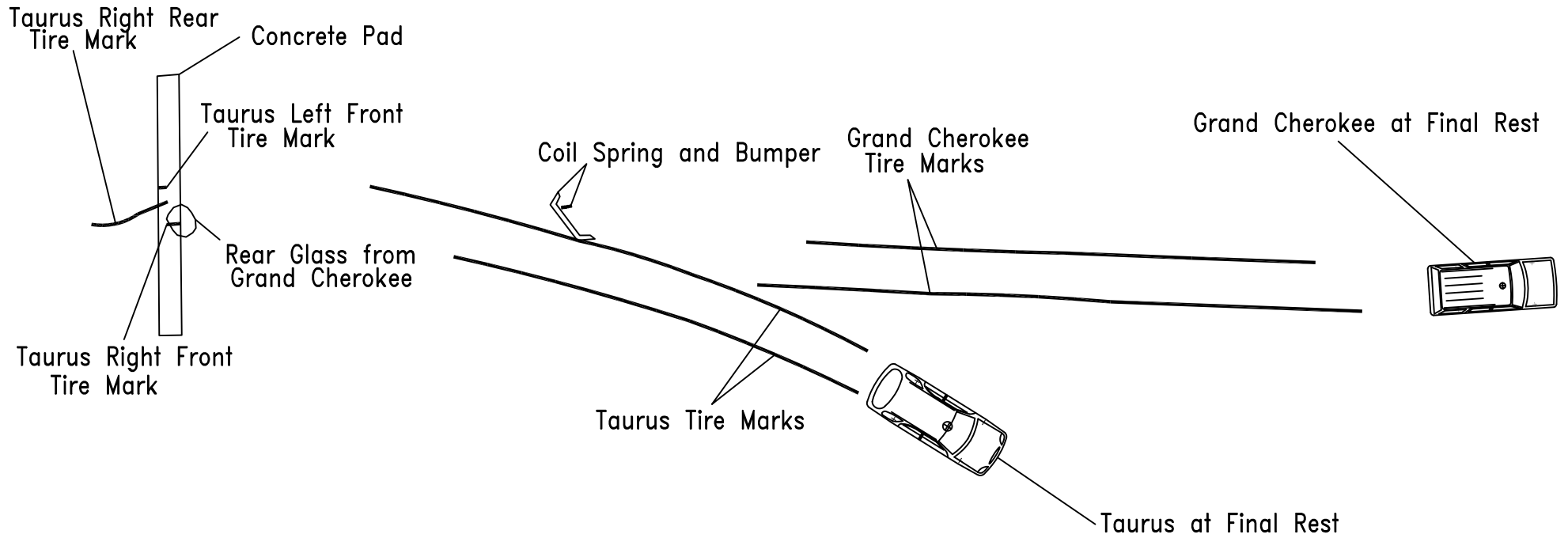

Taurus-Grand Cherokee Rear Impact
50 mph, 70% Overlap



North

Scale in Feet:

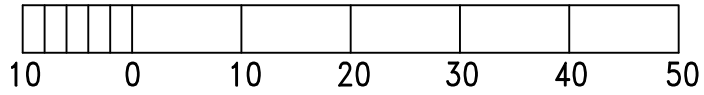

Vehicles at Impact

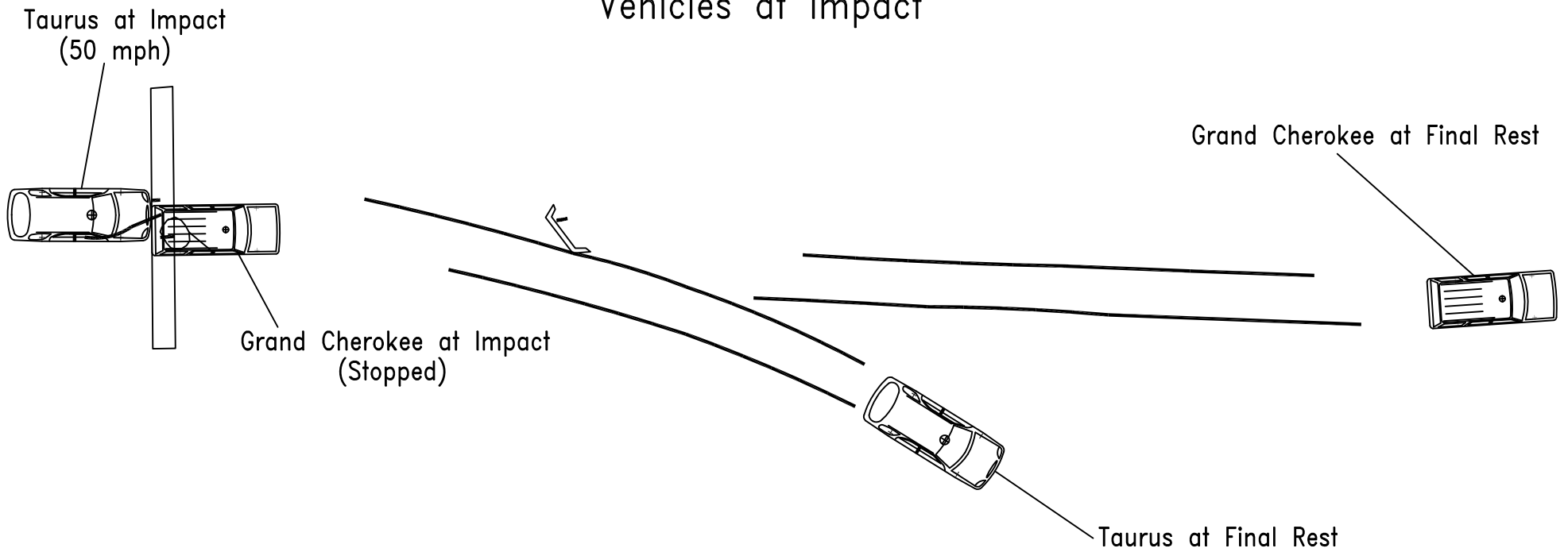

Taurus-Grand Cherokee Rear Impact
50 mph, 70% Overlap



North